

- **C33R-UC** 35-5/8"L x 34-1/4"D x 32-3/4"H
- **C43R-UC** 47-5/8"L x 34-1/4"D x 32-3/4"H
- **C53R-UC** 59-5/8"L x 34-1/4"D x 32-3/4"H
- **C63R-UC** 71-5/8"L x 34-1/4"D x 32-3/4"H

### Included

- Casters (non-locking) w/ levelers
- Condensate pan
- E-Coated evaporator coil
- Hydrocarbon refrigerant (R290)
- Magnetic air filter
- One piece formed ABS plastic tub
- One year parts & labor; 5 year compressor warranty
- Rear wall spacer (removable to fit through door opening)
- Top light (LED 4000K)
- Warmest average product temperature of 40°F or less



**C33R**

Specify	Standard Features	Additional Options
<b>EXTERIOR COLOR</b>	• Powder coated Silversan Black	• Laminate (stock/non-stock colors) • Powder coated (stock/non-stock colors) • Stainless steel
<b>INTERIOR COLOR</b>	• Powder coated Silversan Black	• Stainless steel
<b>REAR EXTERIOR COLOR</b>	• Powder coated Silversan Black	• Stainless steel
<b>BASE SUPPORT</b>	• Casters (non-locking) w/ levelers	• Casters (non-locking) w/ seismic levelers
<b>END PANELS</b>	• Full w/stainless steel mirror interior	• None (synchronized defrost required)
<b>COVER/CURTAIN</b>	• None	• Night curtain, retractable, non-locking • Removable solid security cover, locking
<b>DISPLAY STEPS</b>	• None	• 2"H Full depth display step(s)
<b>PRICE TAG MOLDING</b>	• None	• Universal price tag molding (clear w/ open top)
<b>REAR DOORS</b>	• None (solid back panel)	
<b>ELECTRICAL CONNECTION</b>	• 6' Straight blade power cord	• 6' Locking power cord
<b>CLEAN SWEEP</b>	• None	• Clean Sweep® automatic condenser coil cleaner
<b>REFRIGERATION</b>	• Breeze~E (Type-II) self-contained refrigeration (rear access)	• Breeze~E (Type-II) self-contained refrigeration (front access)
<b>THERMOMETER</b>	• Spirit filled thermometer	
<b>MISCELLANEOUS</b>		• Second year parts & labor warranty (excludes compressor)

**Option Notes:** 1 - One cover/curtain type per model

<b>Intended Environment:</b> Type II - Designed to operate in ambient conditions of 80°F and 55% relative humidity unless noted otherwise in system information below.		
<b>Zone</b>	<b>Intended Product To Be Displayed</b>	<b>Warmest Avg Prod Temp ° F</b>
1	Packaged refrigerated products	40

### PLAN VIEW

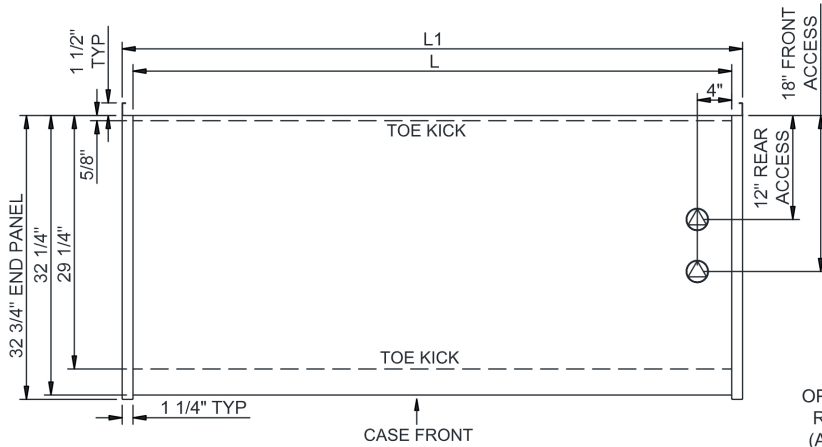

### SIDE VIEW

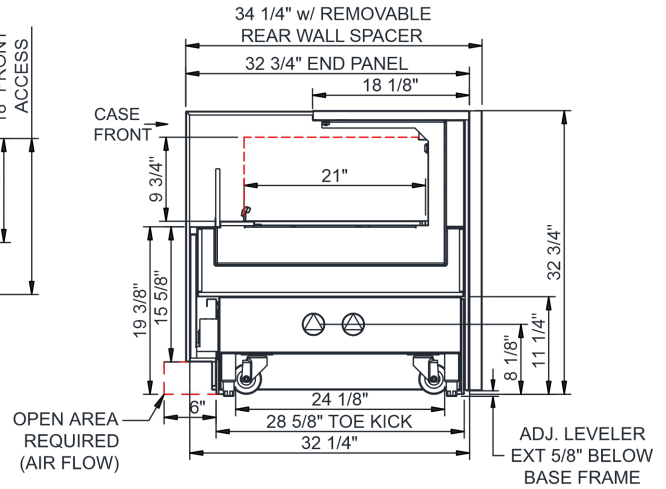

**NOTES:**

1. SELF-CONTAINED ACCESS ONLY BY PULLING OUT CONDENSER DRAWER
2. COMPRESSOR REAR INTAKE, FRONT DISCHARGE AT TOE KICK. REAR & FRONT PANELS CANNOT BE BLOCKED. (INTAKE/DISCHARGE REVERSED WHEN FRONT ACCESS)
3. REAR SPACERS REQUIRED WITH FRONT ACCESS REFRIGERATION

**NOTE: ALL DIMENSIONS APPROXIMATE**

- ELECTRICAL JUNCTION BOX (SUPPLIED WITH 6" LEADS OR POWER CORD).
- LOCATION OF DRAIN TUBE FOR REMOTE REF. ONLY (SUPPLIED WITH 3/4" OR 1 1/2" PVC TUBE).

- REFRIGERATION LINE CONNECTION.
- REMOTE FLOOR SINK & UTILITIES ACCESS AREA.

- SELF-CONTAINED CASE SERVICE ACCESS AREA.
- DRY CASE SERVICE ACCESS AREA.

Model Technical Specifications																
Model	L"	L1"	L2"	System Circuit Volts			Phs	Freq	Amps ***	Watts	Wires	NEMA Plug	SST	Conv. Rack RTU#	Para. Rack RTU#	Est Wt
C33R-UC	33.13	35.63	.00	Self-Contained (R290)	Circuit #1	110-120	1	60	10.85	965	2+G	5-15P or L5-15P	N/A	N/A	N/A	650
C43R-UC	45.13	47.63	.00	Self-Contained (R290)	Circuit #1	110-120	1	60	11.35	994	2+G	5-15P or L5-15P	N/A	N/A	N/A	700
C53R-UC	57.13	59.63	.00	Self-Contained (R290)	Circuit #1	110-120	1	60	15.70	1,531	2+G	5-20P or L5-20P	N/A	N/A	N/A	750
C63R-UC	69.13	71.63	.00	Self-Contained (R290)	Circuit #1	110-120	1	60	15.74	1,540	2+G	5-20P or L5-20P	N/A	N/A	N/A	850

\*\*\* Does not include electric defrost on freezer models.

**Regulatory Approvals:**

All Models  
 Accordance with AHRI Std 1200  
 ETL Listed to UL 471  
 ETL Listed to CAN/CSA 22.2 No. 120  
 ETL Sanitation to NSF/ANSI 7



In Accordance with  
**AHRI Std 1200**

**DOE 2017**  
 Energy Efficiency  
 Compliant

**Important Notes:**

- 1) Performance issues (product temperatures, water on floor, etc.) caused by adverse conditions are not covered by warranty.
- 2) Levelers must be adjusted during installation to ensure unit is level and plumb.
- 3) Keep unit at least 15' from exterior doors, overhead HVAC vents, or any air curtain disruption.
- 4) Do not expose unit to direct sunlight or any heat source (ovens, fryers, etc.).
- 5) Front access compressor air intake at lower front, discharge from lower rear. Lower panels cannot be blocked. Wall spacers required for proper air flow. Rear access reverses air flow direction.
- 6) If GFCI is required, a GFCI breaker MUST be used in lieu of a GFCI receptacle.

**⚠ WARNING:** This product can expose you to chemicals, including Urethane (Ethyl Carbamate), which are known to the State of California to cause cancer and birth defects or other reproductive harm. For more information go to [www.P65Warnings.ca.gov](http://www.P65Warnings.ca.gov).