



**BEVERAGE-AIR®**

PROJECT: \_\_\_\_\_  
 ITEM # \_\_\_\_\_ QTY: \_\_\_\_\_  
 MODEL # \_\_\_\_\_  
 AIA # \_\_\_\_\_ SIS # \_\_\_\_\_  
 APPROVED: \_\_\_\_\_

**TOP MOUNT CROSS TEMP®**

**Model: CT12-12HC-1HSD**

**HALF SOLID DOOR WITH DRAWERS / DUAL-TEMP / REACH-IN REFRIGERATOR/FREEZER**



**7 YEAR WARRANTY  
 Parts, Labor, and Compressor**

**CABINET CONSTRUCTION**

- Exterior is stainless steel front with continuous coil coated sides
- Interior liner is made of corrosion resistant aluminum
- LED lighting
- Door lock
- Expansion valve technology
- Easily converts from refrigerator to freezer
- Dual cabinet configurable to all menu initiatives, temperature range of -15 to 40° F
- Modulates coil temp to achieve desired set point
- Intuitive compressor
- Variable speed compressor technology achieve 30% more energy efficiency
- Quicker pull-down
- Improved product stability
- Two (2) epoxy coated shelves
- Two (2) bottom drawers
- 6" Casters with (2) brakes



**OPTIONS & ACCESSORIES**

- Stainless steel exterior tray slide (kit #4)
- Stainless steel interior
- Stainless steel tray slide (A)
- Universal tray slide (AC)
- Epoxy coated wire rod
- Additional shelves
- Left hand hinged
- 3" Casters
- 6" Flanged legs

**REFRIGERATION SYSTEM**

- Uses environmentally friendly, energy efficient R290 refrigerant, and meets all regulatory requirements for CARB, SNAP, DOE & more
- Variable speed compressor technology achieve 30% more energy efficiency
- Adaptive defrost
- Epoxy coated evaporator coil



# BEVERAGE-AIR®

## Cross Temp® Model: CT12-12HC-1HSD

PLAN VIEW

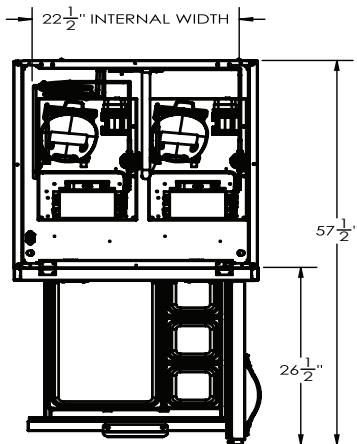

ELEVATION VIEW

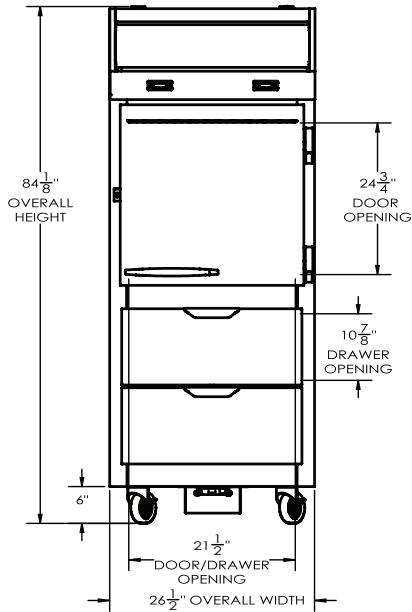

SIDE VIEW

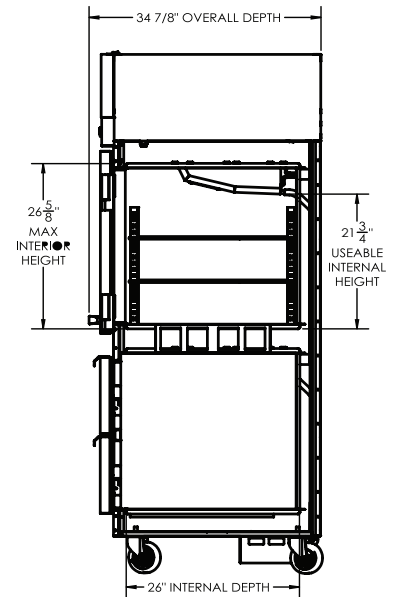

### EXTERNAL DIMENSIONAL DATA

Width Overall (in)	26 1/2"
Depth Overall (in)	34 7/8"
Height Overall (in)	84 1/8"
Number of Doors	1
Number of Drawers	2
Depth with Door open 90° (in)	57 1/2"
Drawers Openings (in)	21 1/2" x 10 7/8"
Door Openings (in)	21 1/2" x 24 3/4"

### INTERNAL DIMENSIONAL DATA

NET Capacity (cubic ft.)	(2) 9.0
Internal Width Useable (in)	22 1/2"
Internal Depth Overall (in)	26"
Internal Height Overall (in)	26 5/8"
Number of Shelves	2

We reserve the right to change specifications and product design without notice. Such revisions do not entitle the buyer to corresponding changes, improvements, additions or replacements for previously purchased equipment. Dimensional tolerances +/- 1/4". Metric dimensions (MM).

\* NOTE: Units that utilize variable speed compressor technology can experience nuisance tripping on Class A GFCI outlets which have a trip limit of 4 to 6 mA. To avoid this issue in a location that requires GFCI circuit protection, Beverage-Air recommends using either an Eaton, SGF20, or HUBBELL Model Number GFRST83W 20A Heavy Duty Hospital Grade Self-Test GFCI Receptacle.

Required Clearance: Top 12" & Rear 3"

### ELECTRICAL DATA

Full Load Amps	7.5
Voltage	115/60/1 *
Nema Plug (8' cord)	(2) 5-15P

### REFRIGERATION DATA

Horsepower	(2X) 1/3
Capacity (BTU/Hr)	(2X) 1820 - 5200
Heat Rejection (BTU/Hr)	(2X) 2730 - 7800
Charge (lbs/grams/ounces)	(2X) 0.165 / 75 / 2.64

### SHIPPING DATA

Gross Weight - Crated	394 lbs.
Height - Crated (in)	88"
Width - Crated (in)	35"
Depth - Crated (in)	36"

### ELECTRICAL CONNECTION



115/60/1  
5-15P

Unit pre-wired at factory and include (2) 8' long cord and plug set.

3779 Champion Blvd., Winston-Salem, NC 27105 | 888-845-9800 | Fax: 336-245-6453 | Beverage-Air.com | Sales@bevair.com

Date Issued 9/25 | Printed in U.S.A.