

IRINOX

The Freshness Company®

Item No.:

Qty.:

Project:

EF NEXT XS

The Essential, Easy and Safe blast chiller choice

EasyFresh® Next blast chillers are the most cost-effective blast chillers in the industry. IRINOX blast chillers rapidly cool foods to +37°F or shock freeze foods to 0°F at the core. This includes hot foods just removed from the heat source. The operating principle of a blast chiller is to extract the heat from the food in the shortest possible time. EasyFresh® Next guarantees ultra-rapid blast chilling and shock freezing to preserve the flavor, colors, textures, aromas, moisture and nutritional value, preserving its yield, quality and freshness longer over time.

Capacity

Number of steam table pans (3): 12"x20"x2.5"

Number of sheet pans (3): 9" x 13"

*Note: Based on 2"3/4 spacing

Yield

Rapid blast chilling cycle capacity (+194°F / +37°F) 22lb

Rapid freezing cycle capacity (+194°F / 0°F) 22lb

*Note: Thinner foods may allow more sheet pan capacity. Tests carried out in compliance with the IRINOX procedure using 2" thick food products

Product Warranty Protection

- 2 years, parts and labor.
- 5 years, compressor.

Certification



Standard Construction Details

- One (1) stainless steel wire shelf 12 51/64 x 20 55/64.
- Door opening on the left with hinges on the left.
- Door with swing closure.
- Single point core temperature probe.
- IRINOX BALANCE SYSTEM®, is a design system created by IRINOX and applied to the whole range of blast chillers. Compressor, condenser, evaporator, and ventilation are balanced to interact perfectly with each other. The goal of the IRINOX BALANCE SYSTEM® is to always guarantee the freshness and original quality of the product.
 - Condenser: designed by IRINOX, it guarantees the performance declared in Climate Class 4.
 - Evaporator: designed by IRINOX with cataphoresis treatment and new generation epoxy resin coating which provides considerable resistance to chemical and environmental corrosion.
 - Ventilation: use of high efficiency one-speed fans.
 - Compressor: highest efficiency and performance on the market.
- 304 stainless steel internal and external material.
- CFC-free high-density polyurethane insulation.
- Full width door with low temperature resistant magnetic gasket.
- Self-contained, air-cooled, energy efficient condensing unit, with R404a refrigerant gas in sealed system.
- Indirect air distribution and special airflow pattern to ensure perfect temperature uniformity .
- 4 adjustable feet: 4" to 5 1/3".
- Maximum cleanliness and hygiene facilitated by rounded corners and components in the chamber in compliance with NSF standards.
- Front mounted USB Data port for data transfer to HACCP software.
- End of cycle hold mode.
- Manual defrosting required daily.
- Conveniently located and removable condensation tray.
- Power cord included (no plug).
- Intuitive touchscreen display.
- Easily accessible evaporators, waterproof fans, and removable magnetic condenser filter.

Unique Design and Performance Features

- EasyFresh® Next cooling cycles rapidly lower the core temperature of the food to +37°F directly from its heat source, quickly reducing bacterial proliferation which is the number one cause of foods' natural deterioration process.
- EasyFresh® Next has two cycles dedicated to cooling:
 - Delicate +37°F: suitable for products that are thin or light in density such as mousses, creams, fish, rice, vegetables, etc.
 - Strong +37°F: ideal for dense, large-sized, or packaged products such as meats, soups, sauces, casseroles, etc.
- EasyFresh® Next's freezing cycles transform the water contained in food into microcrystals that preserve foods' natural structure and quality for much longer. EasyFresh® Next has 2 freezing cycles:
 - Delicate -0°F: works in two phases; one phase at positive temperatures and the other at negative. This cycle is best for hot products such as savory, pastry, leavened bakery items and dense proteins.
 - Strong -0°F: quickly freezes room temperature or below products down to -0°F at their core with an air temperature reaching -31°F. This is also ideal for stabilizing the structure of ice cream, proteins, cooked products, etc.
- Per production cycle (depending on product density):
 - Blast Chilling: up to 90 minute cycle.
 - Shock Freezing: up to 240 minute cycle.
- Automatic recognition of manual work mode (timed) or automatic mode (with probe inserted at the beginning of the cycle).

Options and Accessories

- Low Profile Legs – Height 2" 3/8 - 3" 5/32.

EF NEXT XS – CABINET DIMENSIONS

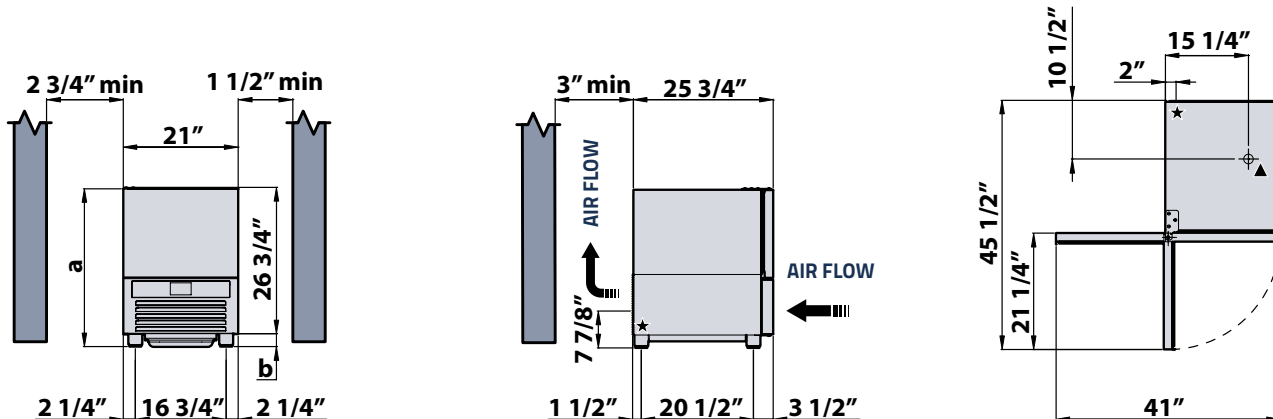

HEIGHT

		a	b
Standard feet	in	30 5/7" - 32 5/64"	4" ± 5 1/3"
Castors option	in	30 1/4"	3 3/7"

Measurement in inches

★ Main power cable

▲ Drain pipe (Ø 1 1/4")

TECHNICAL SPECIFICATIONS

Electric supply		115V - 1PH - 60Hz	
Power rating	W	800	
Full load amps (FLA)	A	6.0	
Main power cable	gauge	2C + G AWG14	
Compressor rating	HP	0.4	
Refrigeration yield (+14/+104°F; Suction Temp +68°F; Subcooling OK)	btu/h	5510	
Condenser rating (+14/+104°F; Suction Temp +68°F; Subcooling OK)	btu/h	8330	
Minimum required air flow for ventilation	ft³/h	30370	
Refrigerant gas type	-	R404a	
Nominal refrigerant charge	oz	23	
Climate class (= max ambient temp)	°F	4 (= 86°F / 30°C)	
Dimension (width x depth)	in	21" x 25 3/4"	
Internal cell dimension (width x depth x height)	in	12 7/8" x 21 5/8" x 12"	
Cabinet weight	Lb	159	

INSTALLATION NOTES

Compressor requires 3" minimum rear wall clearance or 1 1/2" right or left clearance.

Unit must be clear of outside heat sources.

The blast chiller must be installed by following and complying with the contents of the specific installation manual.

The content of the manual must be carefully followed to ensure correct operation and to protect the rights of the user based on the warranty.

Appliance may be equipped with L6-15P Nema plug.

Continuous product development may require changes to specifications without notice.