



# UR27B-LPD2

## Undercounter 27" Low Profile Refrigerator with Two Drawers



UR27B-LPD2  
10/27/25  
Item # 13711

### W x D x H

27" x 30" x 31.9"\*  
\*with 2.25" casters



Item #: \_\_\_\_\_

Project: \_\_\_\_\_

Qty: \_\_\_\_\_

AIA#: \_\_\_\_\_

## Features

► Specifically designed to fit under an ADA compliant 34" work surface height counter



► Engineered to maintain NSF-7 temperatures in 100°F ambient

► Stainless steel exterior front, sides and top with stainless steel interior sides, back, and floor

• Environmentally friendly R290 hydrocarbon refrigerant

• Cabinet and drawers are insulated with 2" CFC free, foamed in place polyurethane

• Drawer slides are constructed of 16 gauge stainless steel with acetal rollers

• Drawer frames are formed of 14 gauge stainless steel and securely fastened in the cabinet

• Top drawers will accommodate (1) 12 x 20 full size pan and (2) ¼ size pans. Bottom drawer will accommodate (1) full size pan.

• Top and bottom drawers allow for 6" deep pans

• Extruded aluminum flush mount drawer handle

• Magnetic drawer gasket is easily removable for cleaning

• Drawers have a 175 lb. dynamic load rating

• Hot gas condensate removal

• E-coated evaporator coil

• Standard with 2.25" casters (two with brakes)

• 10 ft. cord and plug



### Dimensions / Capacity

	One-Section UR27B-LPD2
Interior Storage Capacity (CF) (AHAM)	6.21 ft <sup>3</sup>
Overall Width x Depth (including 1" bumper)	27" x 31"
Height (including 2.25" casters)	31.9"
Drawer Opening Width x Height	22.75" x 23"
Depth with Drawer Fully Open (including 1" bumper)	51"
Crated Weight	203 lbs.
Crated Length x Width x Height	34" x 31.5" x 35.5"

### Electrical / Refrigeration

	One-Section UR27B-LPD2
Voltage	115/60/1
HACR Breaker	15.0 Amps
Electrical Connection (NEMA)	5-15P Ⓢ
Voltage Range	104-126
Ambient Temp. Range	45° to 100°F
Control Setpoint Range	32° to 52°F
Amperage	3
Energy Consumption (kWh/day) @ASHRAE	0.65
Heat Rejection (BTU/Hr.) @NSF	152
Approx. Nominal Compres. BTU/HR (HP)	798(1/6HP)
Refrigerant / Charge Amount (oz)	R290 (2.3 oz)

### Options

- 4" Casters (HS-5035, set of 4)
- 6" Casters (HS-5036, set of 4)
- Drawer liner (HS-5736, upper)
- Drawer liner (HS-5737, lower)
- Stainless steel back panel (factory request)
- Overshelves (HS-5172 single)
- Overshelves (HS-5163 double)
- Drawer divider bar (HS-4007, vertical)
- Drawer divider bar (HS-5433 horizontal)



Seven year warranty on labor, parts, and compressor. Valid in United States, Canada, Puerto Rico and U.S. Territories.

For more information, please visit [hoshizakiamerica.com/support/warranty/](http://hoshizakiamerica.com/support/warranty/)

If GFCI is required, a GFCI breaker MUST be used in lieu of GFCI receptacle

Hoshizaki reserves the right to change specifications without notice.



# UR27B-LPD2

## Undercounter 27" Low Profile Refrigerator with Two Drawers



UR27B-LPD2  
10/27/25  
Item # 13711

### FRONT VIEW

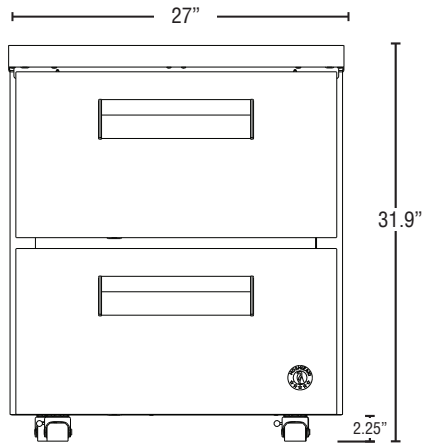

### SIDE VIEW

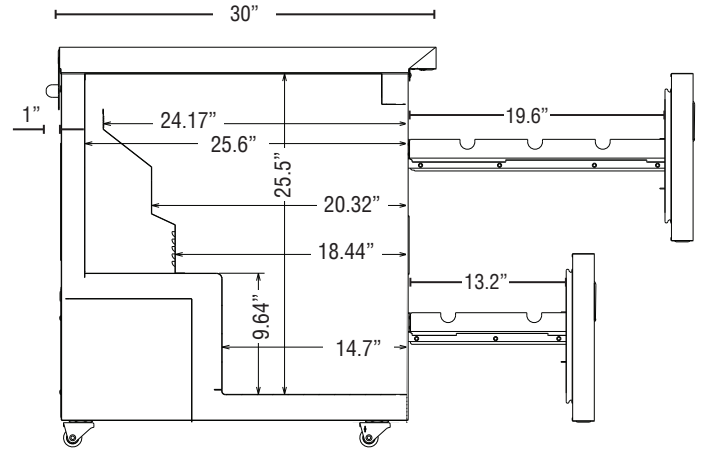

### PLAN VIEW

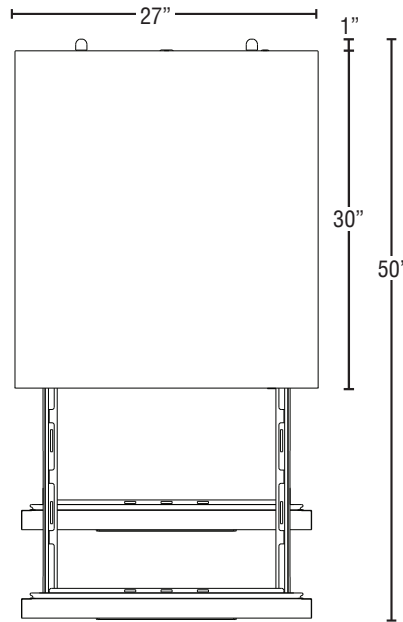

#### Cabinet Construction

The exterior cabinet top, front, and sides, are constructed of high quality stainless steel. The exterior back and bottom are constructed of coated steel. The cabinet interior features stainless steel back, sides, and floor with an ABS top. One heavy duty epoxy coated shelf per section is standard. Mounted on anodized aluminum pilasters the shelves are adjustable in 1/2" increments. Cabinet walls are insulated with 2" CFC free, foamed in place polyurethane. 2.25" polyolefin, stem casters (two with brakes) are standard.

#### Drawer Construction

Drawer fronts are constructed of high grade stainless steel inside and out and drawers are insulated with 2" free foamed in place polyurethane. Drawer frames are formed of 14 gauge stainless steel and securely fastened in the cabinet. The drawer slides are 16 gauge stainless steel with acetal rollers to prevent metal to metal contact between the drawer slides and reduce wear. The drawer slides have a dynamic load capacity of 175 lbs. and have been life tested (fully loaded) three hundred thousand openings and closings without showing significant wear. The flush mount handles are constructed of extruded aluminum. Snap-in magnetic drawer gaskets are durable and easily removed for cleaning. The bottom drawer will accommodate (1) full size pan and the top drawer will accommodate (1) 12x20 full size pan & (2) 1/4 size pans. The top and bottom drawers will accommodate 6" deep pans. Full size pans can be oriented in the top drawer front-to-back or left-to-right. If oriented front-to-back, drawer comes standard with drawer divider. If top drawer pans are oriented left-to-right, then HS-5433 is required for this configuration.

#### Refrigeration System

The high efficiency refrigeration system is self-contained with an E-coated evaporator for extended life. Condensate removal is accomplished with an energy efficient non-electric evaporation system. A capillary tube controls the flow of environmentally friendly R290 refrigerant through the evaporator. Refrigeration system utilizes an "off cycle" defrost to eliminate any ice on the evaporator coil. 115 volt units are equipped with a ten foot cord and plug (20.0 amps or less).