



SPECIFICATIONS

- Two-group fully automatic electronic espresso machine with 1 to 4 cup simultaneous delivery capability.
- Elevated group to fit tall size cups. Available also with deep drip tray, little grid sliding and little spout to accommodate cups from 3,15" to 5,90".
- Large-capacity of nickel-plated copper boiler for continuous dispensing and strong steam supply.
- Three portion selectors for group with continuous delivery and a stop button.
- Heat-balancing units with pre-infusion for optimal espresso extraction.
- Insulated boiler to save energy consumption.
- Hot/Cool Water Mix.
- Steam taps with quick opening.
- New steam nozzles with anti-scald system to facilitate use.
- Steel buttons
- Ideal for any size operation of espresso bar, hotel, restaurant or cafe featuring advanced technology and ultra-modern design for today's market
- Available colors: Black, White



VITTORIO RS 2GR

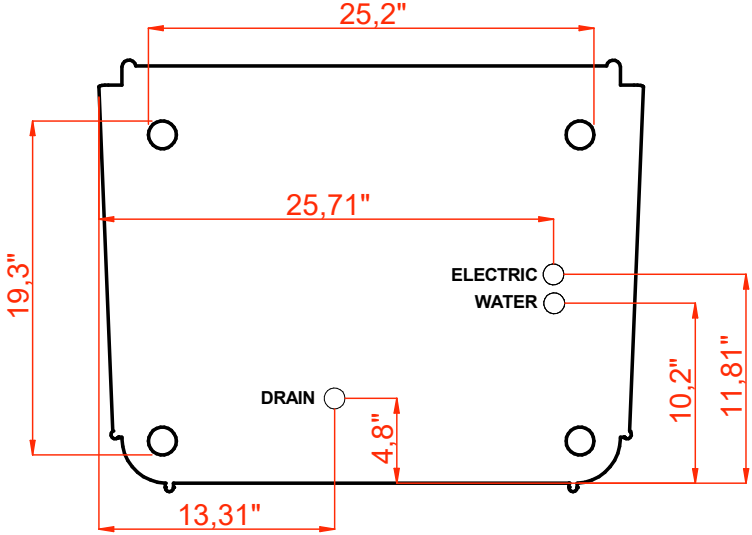
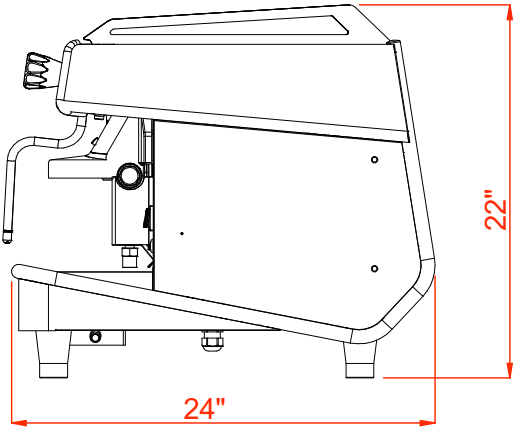
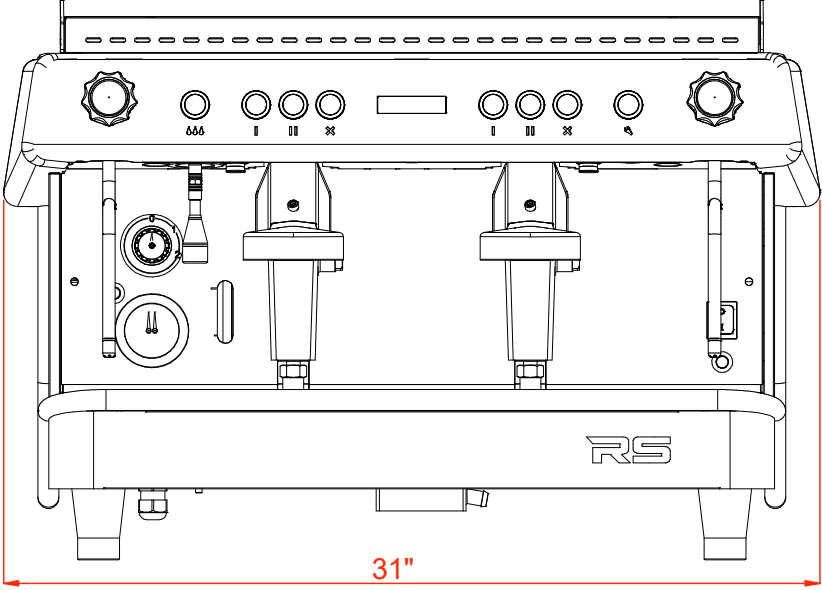

BOTTOM VIEW

BREW DEVICE	CUPS PER GROUP	W / D / H	BOILER CAP (LITERS)	V.	AMP.	PH.	Hz.	WATTS	WT. (Kg/lbs)	INCOMING H2O	DRAIN	MIN/MAX bar
									SHIP. WT. (Kg/lbs)			
2	2	31" x 24" x 22.5"	14	220	19	1	60	4000	77/170	3/8" MALE	Ø9mm INTERNAL	2 / 5
									84/185			