



# SPEC SHEET

## KoolMore 71 in. Three-Door Merchandiser Refrigerator - 56 Cu Ft.

Model: MDR-3GD-63C

### FEATURES

- Automatic Defrost and Dynamic Cooling System.
- LED Interior Illumination.
- Double-Sided, Double-Layer Tempered Glass.
- Adjustable Shelving.
- Self-Evaporation Water Tray.
- Anti-fogging system.



### CLOSE UP IMAGES



# TECHNICAL SPECS

## Dimensions

Length	67.32
Height	81.26
Width	28.54
Interior Depth	23.43
Interior Width	63.5
Interior Height	61.48
Shelf Width	"19.88 (left&right) 22.59(middle)"
Shelf Depth	21.73
Depth Excluding Handles	27.16
Depth Including Handles	28.35
Depth Less Door	25.39
Depth With Door Open 90 Degrees	48.94
Minimum Back Air Clearance In	4 in.
Minimum Side Air Clearance In	4 in.
Power Cord Length	98

## Capacity

Gross Cubic Feet	48.9
Net Cubic Feet	40.7
Individual Shelf Capacity	71.65

## Features & Materials

Door Style	Swing
Number Of Doors	3
Number Of Shelves	15
Defrost Type	Automatic
Refrigerant Type	R-290
Temperature Control Type	
Temperature Range	32-50 F
Ambient Temperature Range	100.4
Light Type	
Casters	8
Interior Material	Galvanized Steel
Exterior Material	Precoated Steel
Shelf Material Type	Coated Metal
Noise	56 db

## Electric & Certifications

Amps	6.8
Phase	1
Voltage	115
Wattage	700
Hertz	60
Plug Type	NEMA 5-15P
Certifications	ETL Listed for Safety and Sanitation

# Plan View

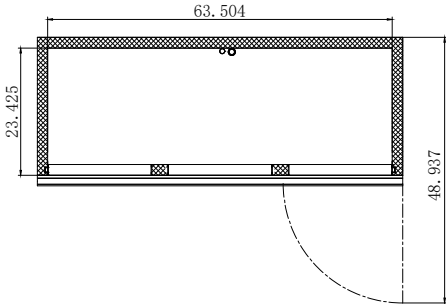
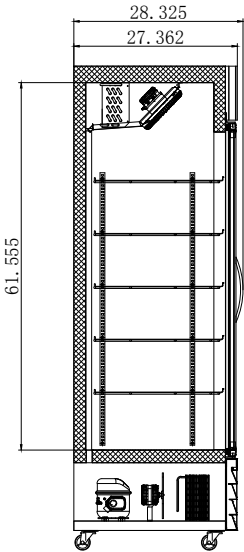
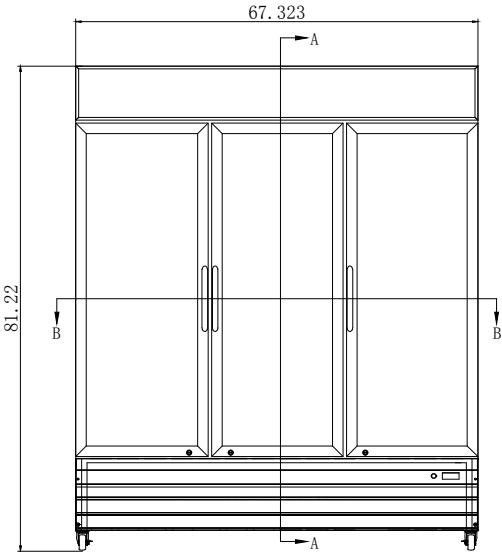

**CERTIFICATIONS**



Intertek Intertek



706 Eastern Parkway STE 1G, Brooklyn NY 11213  
718-576-6342  
info@koolmore.com