



Project _____
 AIA # _____ SIS # _____
 Item # _____ Quantity _____ C.S.I. Section 114000



ABSGDO-801T – SINGLE-DECK TWO-PAN GAS DECK OVEN

ABSGDO-801T – Single-Deck Two-Pan Gas Deck Oven



Model ABSGDO-801T Single-Deck, Two-pans wide

STANDARD FEATURES

- Strong Welded Steel Frame
- Stainless Steel Body Panels
- Digital Controls for Top and Bottom Heat Control Readable in C or F
- Bake Timer, Steam Timer and Interior Light
- Ceramic Stone Hearths - Easily Removed for cleaning
- Thermostatically Controlled Self Cleaning Steam System
- Doors with View Windows open out and Down
- Casters with Levelers on all four corners

CONTROL AND PERFORMANCE FEATURES

- Top and Bottom Heat Control—Easily Readable
- Available in Natural Gas or Propane
- Eight Inch Crown - Bakes Artisan Breads, Cakes and Pastries
- Steam System steam with temperature and moisture control
- Self- Cleaning Stainless Steel Steam Pods
- Oven supplied on Casters with levelers
- Oven supplied with 6 Foot Electrical Cord with NEMA Cord Cap - 110 Volt, 1 Ph
- Steam System supplied with separate 6 foot cord with NEMA Cord Cap – 240 Volt, 1 Ph

OPTIONS & ACCESSORIES

- Steel Hearths
- Stainless Steel Factory

STANDARD PRODUCT WARRANTY

- One Year Parts and Labor (Contiguous USA and Canada Mainland)

MARKETING SPECIFICATION

Specified Gas Bakery Deck Oven shall be an ABSGDO-801T , One deck, Two pans per deck, with a baking area of 39.5” Wide and 31” Deep, Eight inch Crown, solid welded steel frame, Modular construction allowing for up to Two additional decks, and full stainless steel exterior. Each deck shall be supplied with Digital Controls for top and bottom heat control readable in C or F, Bake timer, steam timer. Interior Light, easily removable ceramic stone hearths, self-cleaning steam system with stainless steel pods and thermostatically controlled steam temperature and moisture, and door with windows that open out and down. Oven shall be supplied with casters and levelers on all four corners and exceed ETL/UL and ETL/NSF Listings.



Meets UL 763 and NSF-8 Standards



MPM Food Equipment Group, LLC
 236 Egidi Drive, Suite A, Wheeling, IL 60090
 Phone: 800-976-6762 Fax: 847-297-6725
 Email: info@mpmfeg.com
 WEB: www.mpmfeg.com

Send Orders to: ABSorders@mpmfeg.com



Single-Deck Two-Pan Gas Deck Oven

ABSGDO-801T

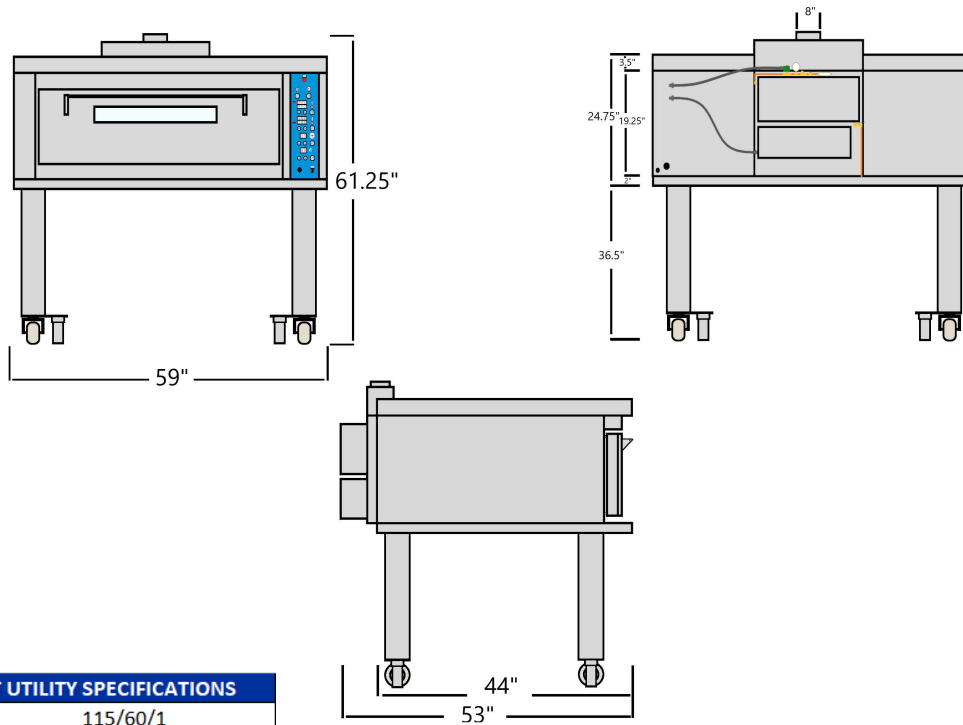

Spacing: 4" from wall in rear and sides. Allow 6-inches above unit from any draft hoods to avoid creating a draft in the baking chamber, which will cause uneven baking. Front of oven should be unobstructed for access to controls and for loading and unloading of product.

MODEL ABSGDO-801T UTILITY SPECIFICATIONS	
Model 801T	115/60/1
Plug	115v plug
Slow-Blow Breaker	10 Amp
Natural Gas	98,000 BTU/HR Min 5" WC Max 14" WC
Propane LPG Gas	103,050 BTU/HR Min 8" WC Max 14" WC
Water	1/2" cold water 20 PSI Maximum Filtered/Softened
Options	Steam: 240/60/1 NEMA 6-50P plug 45 Amp Slow Blow Breaker

MODEL ABSGDO-801T 2-PAN WIDE	
Hearth Dimensions	39" w x 31" d x 8" h 1209 sq inches

SHIPPING							
Model	Crated Dimensions Height x Width x Depth	Unit Dimensions Height x Width x Depth	Weight	Net Weight	Freight Class	Door Clearance	Fork Lift Delivery Recommended
ABSGDO-801T	83" x 66" x 57"	61.25" x 59" x 53"	1600	1100	110	Verify path from loading dock to install location.	Yes



Send Orders to: ABSorders@mpmfeg.com