



The Signature of Quality®

FEDERAL INDUSTRIES

A Standex Company

215 Federal Avenue
Belleville, Wisconsin 53508-9201

Phone: 800-356-4206

Fax: 608-424-3234

Email: Geninfo@Federalind.com

Website: Federalind.com

Project Name: _____

Item #: _____

Model #: _____ Qty: _____

Approval: _____

AIA #

SIS #

VISION SERIES - Curved Ends Self-Serve Refrigerated Slide-In Display Case - 60"

Designed with impulse sales in mind. Get maximum return from an attention-grabbing case and increase profits.



MODEL	DIMENSIONS (Includes End Panels)
<input type="checkbox"/> VRSS3660C-SLD	36 x 33 x 71.6 (in) 914 x 838 x 1819 (mm)
<input type="checkbox"/> VRSS4860C-SLD	47.25 x 33 x 71.6 (in) 1200 x 838 x 1819(mm)
<input type="checkbox"/> VRSS6060C-SLD	59.25 x 33 x 71.6 (in) 1505 x 838 x 1819 (mm)
<input type="checkbox"/> VRSS7260C-SLD	71.25 x 33 x 71.6 (in) 1810 x 838 x 1819 (mm)

STANDARD FEATURES

Model Features

- Black interior including shelves
- Stainless steel display deck
- Tempered glass upper end panels
- Black powder coated base frame
- Black trim
- Rear air intake and discharge
- Adjustable height casters (32" to 38" counter height) with locks
- Cord & plug
- Energy saving night curtain

Refrigeration

- R290 Refrigerant
- Electronic temperature control maintains 38° - 40°F (3.3° - 4.4°C) Note: Case temperatures will vary if the air curtain is disrupted.
- Digital thermometer
- Clear coil on demand defrost
- Coated evaporator coil

Shelving

- Two tiers of adjustable black metal shelves with black price tag molding.
- Shelves can be flat or slanted down at 10°

Lighting

- 3500K LED top light

Agency Approvals

- UL, C-UL, and UL Sanitation listed to NSF-7, Type I conditions
- DOE 2017 compliant

OPTIONAL ACCESSORIES

- | | |
|--|--|
| <input type="checkbox"/> White interior (including shelves) | <input type="checkbox"/> Graphics package |
| <input type="checkbox"/> Stainless steel interior (including shelves) | <input type="checkbox"/> Clear or reflective glass, sliding rear doors (Solid hinged on 36" cases) |
| <input type="checkbox"/> Stainless steel shelves in lieu of black | <input type="checkbox"/> Black polycarbonate removable locking security cover |
| <input type="checkbox"/> Additional lighted 3500K LED shelf | |
| <input type="checkbox"/> 3500K LED lights below shelves | |
| <input type="checkbox"/> Deli meat pegs | |
| <input type="checkbox"/> Field Install - High-capacity condensate evaporator assembly - Separate (1500W 120V, 15 AMP circuit required) | |
| <input type="checkbox"/> Self-cleaning condenser | |
| <input type="checkbox"/> Stainless steel exterior finish | |
| <input type="checkbox"/> Reflective glass end panels | |
| <input type="checkbox"/> Solid end panels (mirrored interior) | |
| <input type="checkbox"/> Premium exterior laminate (upper solid ends only) | |

*Additional options available on the website and price list



WARRANTY*
One year Parts and Labor
2nd thru 5th year part only
service compressor
(U.S.A. and Canada)

Note: Information is subject to change at any time. Visit www.federalind.com for the most current specs.

AIA #	VISION SERIES - Curved Ends Self-Serve Refrigerated Slide-In Display Case - 60"
SIS #	Product Specifications

Intended Environment: Type I - Designed to operate in maximum ambient conditions of 75°F (24°C) and 55% relative humidity.		
Zone	Intended Product To Be Displayed	Avg Prod Temp °F/°C
All	Packaged Refrigerated Products	38°F / (3.3°C)

DIMENSION: xx"/(mm)
DIMENSION TOLERANCE +/- 0.25 (6.4)

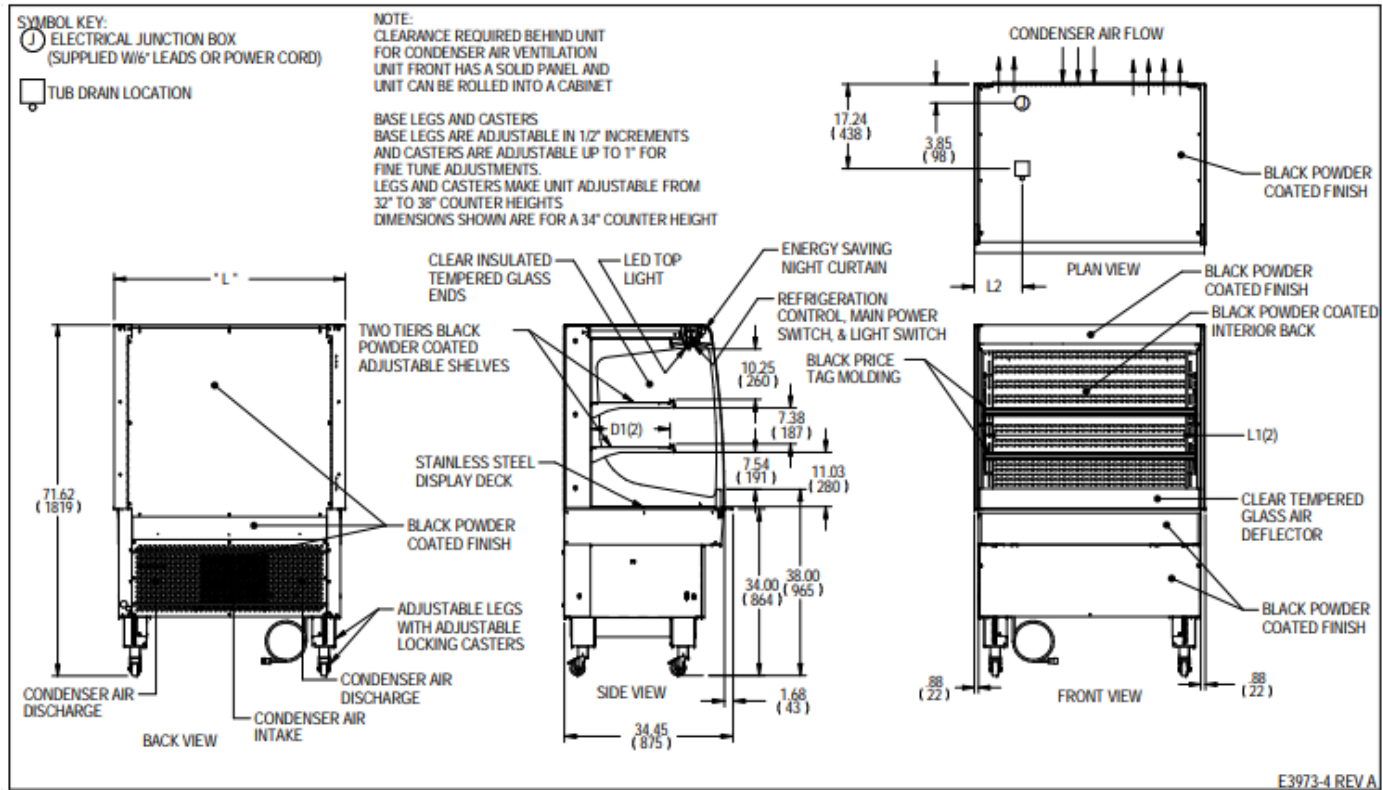

MODEL	DIMENSIONS				TUB DRAIN	SHELVING			INTERIOR VOLUME CU FT	ELECTRICAL 2 WIRE + GROUND	STANDARD CONNECTION CORD & PLUG			REFRIGERANT	C.U. HP	CONDENSATE REMOVAL	SHIP WEIGHT
	L	D	H	L2	# OF TIERS	L1	D1	AMPS			MAX FUSE SIZE	NEMA CORD &					
	in	in	in	in		in	in						in				
VRSS3660C-SLD	36	33	71.6	6.74	2	32.25	16.634	13.98	120/60/1	12.7	20	NEMA 5-20P	R449A	3/4	INTEGRATED PAN	535	
	914	838	1819	171		819	423									243	
VRSS4860C-SLD	47.25	33	71.6	13.49	2	43.25	16.634	18.48	208-240/60/1	12.5	20	NEMA 6-20P	R449A	1	INTEGRATED PAN	620	
	1200	838	1819	343		1099	423									281	
VRSS6060C-SLD	59.25	33	71.6	14.12	2	55.25	16.634	23.39	208-240/60/1	13.5	20	NEMA 6-20P	R449A	1-1/4	INTEGRATED PAN	755	
	1505	838	1819	359		1403	423									342	
VRSS7260C-SLD	71.25	33	71.6	20.12	2	67.25	16.634	28.30	208-240/60/1	13.7	20	NEMA 6-20P	R449A	1-1/4	INTEGRATED PAN	845	
	1810	838	1819	511		1708	423									383	

- Due to continuing engineering improvements, specifications are subject to change without notice.
- Case temperature will vary if the air curtain is disrupted.



FEDERAL INDUSTRIES
 A Standex Company
 215 Federal Avenue Belleville, Wisconsin 53508-9201

Phone: 800-356-4206
Fax: 608-424-3234
Email: Geninfo@Federalind.com
Website: Federalind.com