



BEVERAGE-AIR®

PROJECT: _____
 ITEM # _____ QTY: _____
 MODEL # _____
 AIA # _____ SIS # _____
 APPROVED: _____

TOP MOUNT CROSS TEMP®

Model: CT12-12HC-1HG

HALF GLASS DOOR / DUAL-TEMP / REACH-IN REFRIGERATOR/FREEZER



**7 YEAR WARRANTY
 Parts, Labor, and Compressor**

CABINET CONSTRUCTION

- Exterior is stainless steel front with continuous coil coated sides
- Interior liner is made of corrosion resistant aluminum
- Door locks
- LED lighting
- Expansion valve technology
- Easily converts from refrigerator to freezer
- Dual cabinet configurable to all menu initiatives, temperature range of -15 to 40° F
- Modulates coil temp to achieve desired set point
- Variable speed compressor technology achieve 30% more energy efficiency
- Quicker pull down
- Improved product stability
- Four (4) epoxy coated shelves
- 6" Casters with (2) brakes



OPTIONS & ACCESSORIES

- Stainless steel exterior tray slide (kit #4)
- Stainless steel interior
- Stainless steel tray slide (A)
- Universal tray slide (AC)
- Epoxy coated wire rod
- Additional shelves
- Left hand hinged
- 3" Casters
- 6" Flanged legs

REFRIGERATION SYSTEM

- Uses environmentally friendly, energy efficient R290 refrigerant, and meets all regulatory requirements for CARB, SNAP, DOE & more
- Variable speed compressor technology achieve 30% more energy efficiency
- Adaptive defrost
- Epoxy coated evaporator coil



BEVERAGE-AIR®

Cross Temp® Model: CT12-12HC-1HG

PLAN VIEW

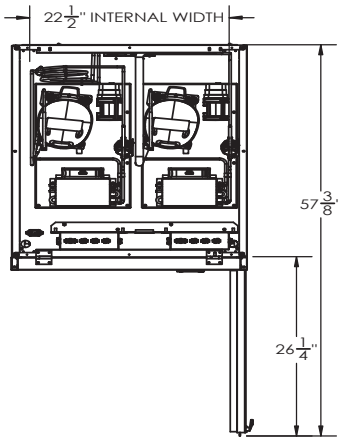

ELEVATION VIEW

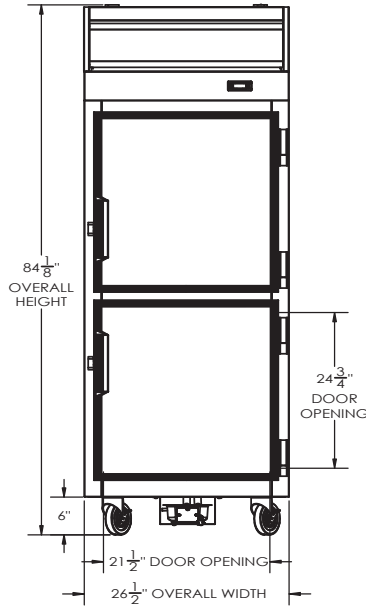

SIDE VIEW

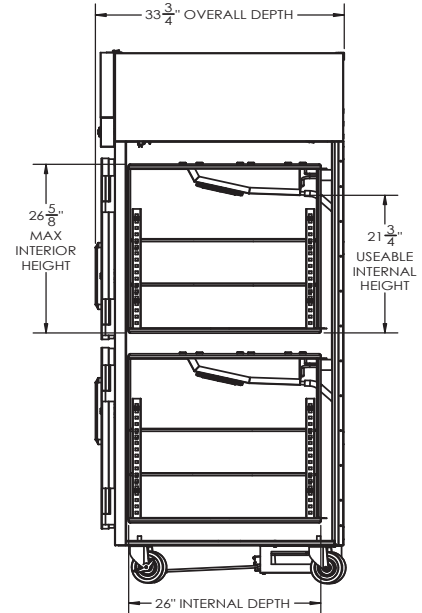

EXTERNAL DIMENSIONAL DATA

Width Overall (in)	26 1/2"
Depth Overall (in)	33 3/4"
Height Overall (in)	84 1/8"
Number of Doors	2
Depth with Door open 90° (in)	57 3/8"
Door Openings (in)	21 1/2" x 24 3/4"

INTERNAL DIMENSIONAL DATA

NET Capacity (cubic ft.)	(2) 9.0
Internal Width Useable (in)	22 1/2"
Internal Depth Overall (in)	26"
Internal Height Overall (in)	26 5/8"
Number of Shelves	4

We reserve the right to change specifications and product design without notice. Such revisions do not entitle the buyer to corresponding changes, improvements, additions or replacements for previously purchased equipment. Dimensional tolerances +/- 1/4". Metric dimensions (MM).

* NOTE: Units that utilize variable speed compressor technology can experience nuisance tripping on Class A GFCI outlets which have a trip limit of 4 to 6 mA. To avoid this issue in a location that requires GFCI circuit protection, Beverage-Air recommends using either an Eaton, SGF20, or HUBBELL Model Number GFRST83W 20A Heavy Duty Hospital Grade Self-Test GFCI Receptacle.

Required Clearance: Top 12" & Rear 3"

ELECTRICAL DATA

Full Load Amps	7.5
Voltage	115/60/1 *
Nema Plug (8' cord)	(2) 5-15P

REFRIGERATION DATA

Horsepower	(2X) 1/3
Capacity (BTU/Hr)	(2X) 1820 - 5200
Heat Rejection (BTU/Hr)	(2X) 2730 - 7800
Charge (lbs/grams/ounces)	(2X) 0.165 / 75 / 2.64

SHIPPING DATA

Gross Weight - Crated	418 lbs.
Height - Crated (in)	88"
Width - Crated (in)	35"
Depth - Crated (in)	36"

ELECTRICAL CONNECTION



115/60/1
5-15P

Unit pre-wired at factory and include (2) 8' long cord and plug set.

3779 Champion Blvd., Winston-Salem, NC 27105 | 888-845-9800 | Fax: 336-245-6453 | Beverage-Air.com | Sales@bevair.com

Date Issued 9/25 | Printed in U.S.A.