



SPEC SHEET

KoolMore 28 in. Commercial One Door Convertible Reach-In Refrigerator/Freezer with 25 Cu. Ft. Capacity in White

Model: KM-RIC-1DWH

FEATURES

- Single solid door ensures security and insulation.
- Durable stainless steel construction with a sleek white finish.
- Convertible function allows for use as a refrigerator or freezer.
- Self-closing door for energy efficiency.
- Adjustable shelves for customizable storage options.
- Bright LED lighting illuminates the interior.
- ETL listed for safety and sanitation compliance.
- Digital temperature display for precise monitoring.



CLOSE UP IMAGES

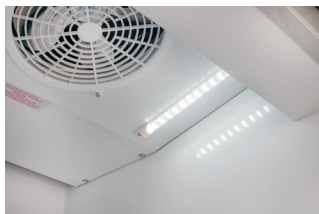

TECHNICAL SPECS

Dimensions

Length	28.34
Width	30.59
Height	77.95
Interior Depth	22.76
Interior Width	26.38
Interior Height	65.35
Weightlbs	320
Depth Excluding Handles	28.35
Depth Less Door	25.79
Depth With Door Open 90 Degrees	57
Height To Top Of Door Hinge In	75.47
Depth Including Handles	28.35
Height To Top Of Case In	77.95
Power Cord Length	110
Minimum Side Air Clearance In	2 in.
Minimum Back Air Clearance In	2 in.

Capacity

Gross Cubic Feet	25
Net Cubic Feet	18.2
Individual Shelf Capacity	50 lbs.

Features & Materials

Shelves Adjustable	Yes
Temperature Range	34-38 F/ -10--7 F
Ambient Temperature Range	100 F
Defrost Type	Automatic
Refrigerant Type	R-290
Cooling Unit Type	Automatic
Number Of Shelves	4
Shabbos Mode	No
Interior Lights	
Temperature Control Type	DIGITAL
Control Type	Digital
Noise	55dB
Conversion Time Refrigerator To Freezer	5 hrs.
Conversion Time Freezer To Refrigerator	5 hrs.
Door Material	Metal
Interior Material	High Impact Polystyrene
Exterior Material	Painted Steel
Interior Cabinet Insulation	Polyurethane
Number Of Doors	1
Door Style	Swing
Reversible Door S	Yes
Color Finish	White
Anti Condensation Glass Heating Strips	

Electric & Certification

Horsepower	0.5
Amps	7
Hertz	60
Phase	1
Voltage	115
Wattage	480
Plug Type	NEMA 5-15P
CERTIFICATIONS	ETL Listed for Safety and Sanitation

Plan View

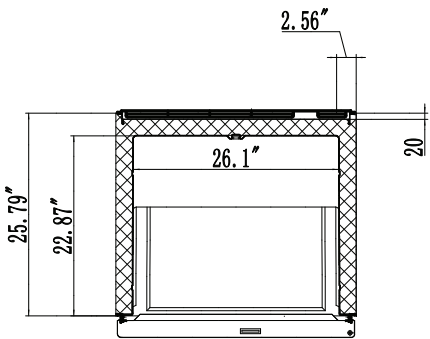
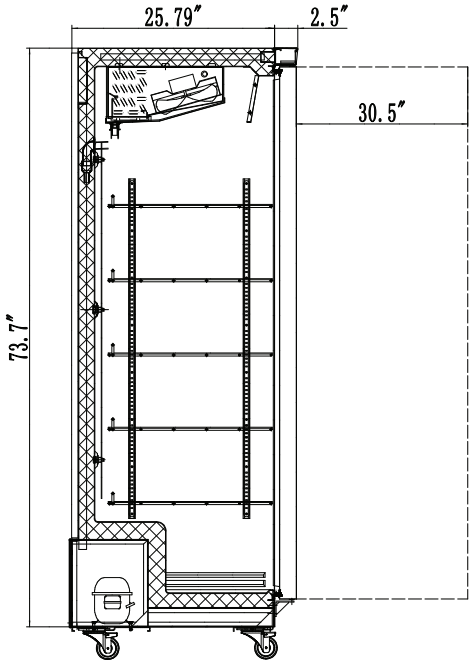
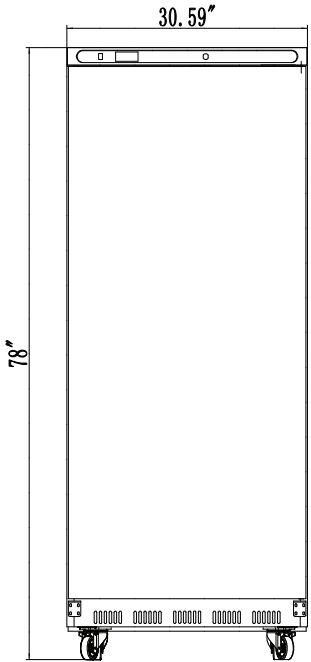

CERTIFICATIONS



Intertek Intertek



718-576-6342
info@koolmore.com