

Company:

Job:

Notes:

Item#:



MANUFACTURING INC.

SHEET PAN RACK - Full Height 20 Tier End-Load

ALUMINUM CONSTRUCTION WELDED (W) OR KNOCK DOWN (KD)

FEATURES

- Heavy Duty 16ga aluminum construction
- 5" dia swivel casters; Two (2) with brakes
- Hold and Transport:
 - 20 Full Size (18"x26") sheet pans
 - 40 Half Size (18"x13") sheet pans
- 3" spacing between each tier
- Ships welded or knocked down

MATERIAL

- Frame: 16ga 1"x1" Aluminum
- Caster: 5" Swivel Rubber

Model #	UNIT SIZE			G.W.
	L	W	H	
SMAPR-20KD	20-1/4"	26"	69"	32 lbs
SMAPR-20W	20-1/4"	26"	69"	33 lbs



WEIGHT CAPACITY FOR DISTRIBUTED LOAD IN LBS

SMAPR-20KD 700 lbs

SMAPR-20W 800 lbs

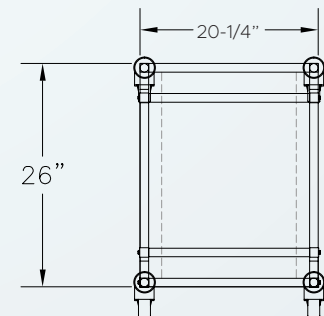
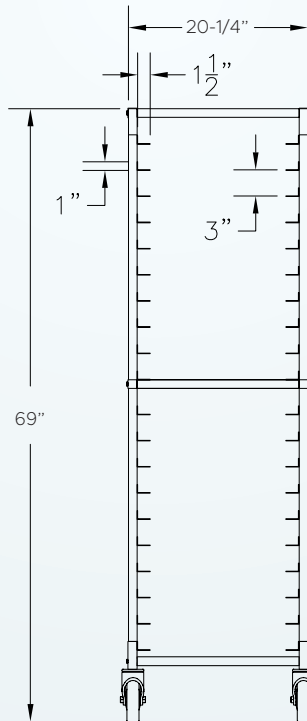
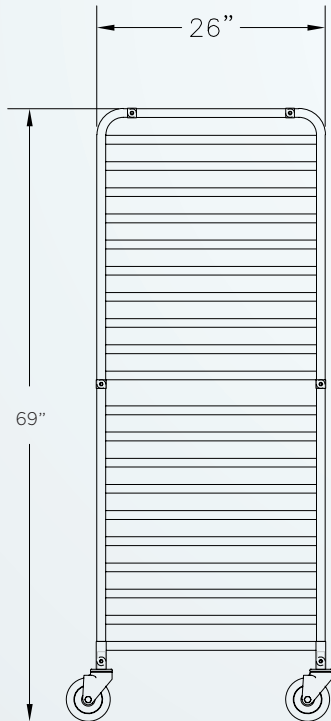

Specifications subject to change without notice - All dimensions are typical (Tolerance 1/4")