



DIRECT STEAM FULL PEDESTAL KETTLE



OPERATION SHALL BE BY:

Direct steam at a minimum of 5 PSI (34 kPa) and a maximum of 35 PSI (241 kPa).

MODEL	CAPACITY	
	KDPS-20F	20 Gallon
KDPS-30F	30 Gallon	114 Liter
KDPS-40F	40 Gallon	152 Liter
KDPS-60F	60 Gallon	227 Liter

OPTIONS & ACCESSORIES AT ADDITIONAL COST

- 50 PSI (345kPa) high pressure operation for higher cooking temperature (HP-50)
- 3" (76 mm) draw-off valve with perforated strainer (TVS-3)
- Triple basket assembly (TBA-)
- Steam trap assembly consisting of steam trap, steam control valve, check valve and line strainer (STA-1)
- Solid stainless steel disc for draw-off valve (TSS-)
- Strainer hook (SH)
- Graduated measuring strip (CMS-)
- Kettle heat shield (KHS-)

STANDARD CONSTRUCTION SPECIFICATIONS

Shall be a Southbend Steam model KDPS-20F, KDPS-30F, KDPS-40F or KDPS-60F, direct steam connected, full jacketed pedestal base kettle.

A double wall kettle interior shall form a steam jacket around the kettle.

The bottom of the kettle shall be of hemispherical design for superior heat circulation.

The kettle interior on model 20 gallon shall be standard stainless steel type 316 for high acid content cooking.

Kettle shall be mounted on stainless steel pedestal base with four

7/16" holes evenly spaced for securing to the floor.

Construction shall be all welded satin finish stainless steel, type 304.

The interior liner shall be standard type 316 stainless steel for high acid content cooking.

Faucet bracket standard.

Convenience features shall include a spring assist hinged stainless steel cover and a 2" (50mm) sanitary draw-off valve with perforated strainer.



Approval Notes: _____

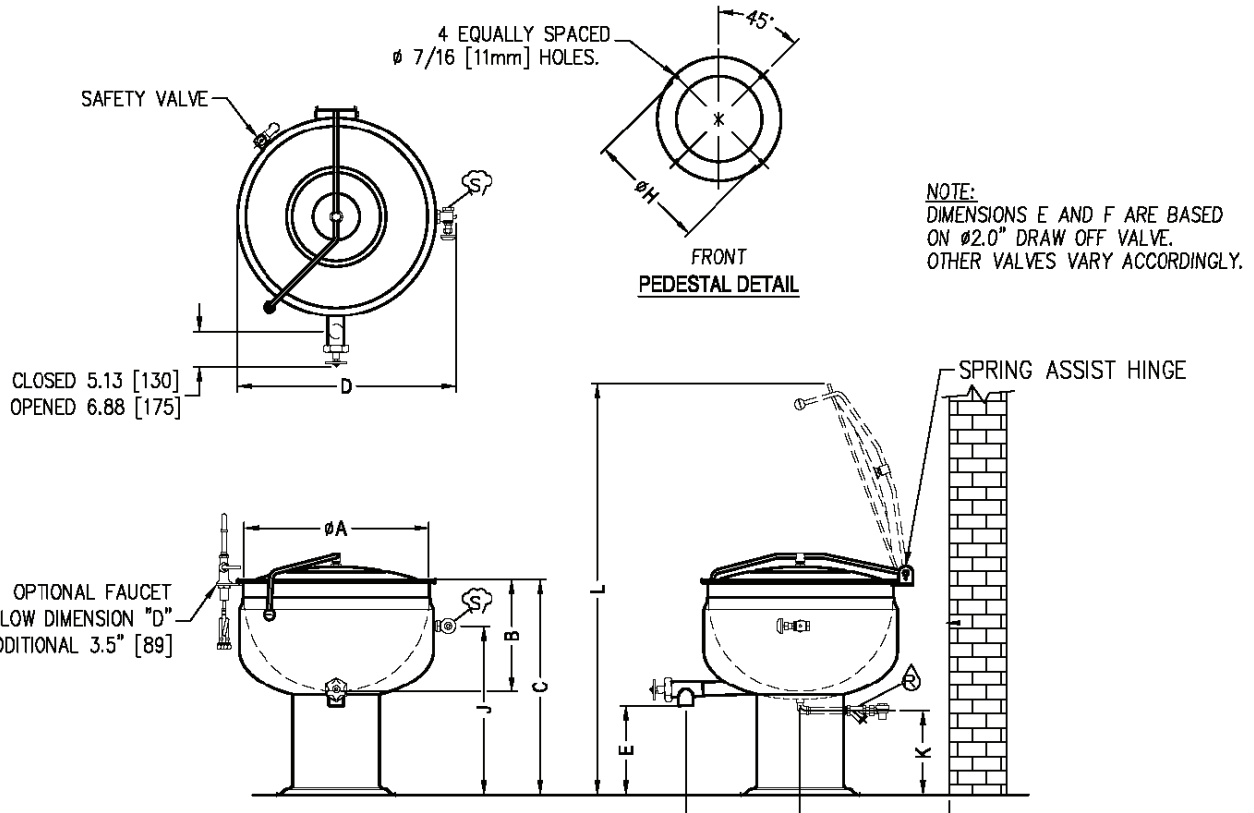

SERVICE CONNECTIONS

- STEAM SUPPLY: 3/4" IPS (19 mm)
- CONDENSATE RETURN: 1/2" IPS (13 mm)

DIMENSIONS

MODEL	CAPACITY	UNITS	A	B	C	D	E	F	G	H	J	K	L
KDPS-20F	20 gallons (76 liters)	in (mm)	26" (660)	15.75" (400)	30.25" (768)	30.75" (781)	12.5" (318)	16.13" (410)	21" (533)	16.63" (422)	23.75" (603)	11.88" (302)	58" (1473)
KDPS-30F	30 gallons (114 liters)	in (mm)	29.5" (749)	17.5" (445)	32" (813)	34.13" (867)	12.38" (314)	17.63" (448)	18.13" (460)	16.63" (422)	24.63" (625)	11.88" (302)	62.88" (1597)
KDPS-40F	40 gallons (152 liters)	in (mm)	33" (838)	19.25" (489)	33.75" (857)	37.63" (956)	12.38" (314)	19.38" (492)	19.88" (505)	19.63" (499)	25.75" (654)	11.88" (302)	67.88" (1724)
KDPS-60F	60 gallons (227 liters)	in (mm)	35.5" (902)	20.5" (521)	35" (889)	40" (1016)	12.38" (314)	20.13" (511)	21.13" (537)	19.63" (499)	26.5" (673)	11.88" (302)	71.63" (18.19)

SPECIFICATIONS

MODEL	SHIPPING WEIGHT	MINIMUM CLEARANCE	
KDPS-20F	175 lbs. [79 kg]	SIDES BACK	3 [76] .5 [13]
KDPS-30F	240 lbs. [109 kg]		
KDPS-40F	280 lbs. [127 kg]		
KDPS-60F	320 lbs. [145 kg]		

**INTENDED FOR COMMERCIAL USE ONLY.
NOT FOR HOUSEHOLD USE.**

