



GOLDEN BROWN FINISH

For more than 25 years, the Vertical Contact Toaster has been a staple in foodservice operations, building a reputation for quality and reliability around the world.

The Vertical Contact Toaster gives buns a consistent, golden brown finish which helps the sandwich stay firm and delicious. The VCT-50 has a preset toast time of 50 seconds.



VCT-50 Vertical Contact Toaster



Dual-Sided Platen

Vertical Contact Toaster has more capacity than conventional single-sided toasters, allowing operators to quickly serve fresh products



Dial Temperature Thermostat

Easily adjust the quality of the toast for a variety of different bread products



Small Footprint

The upright design saves valuable counter space, allowing it to easily integrate into any operation

Vertical Contact Toaster | VCT-50

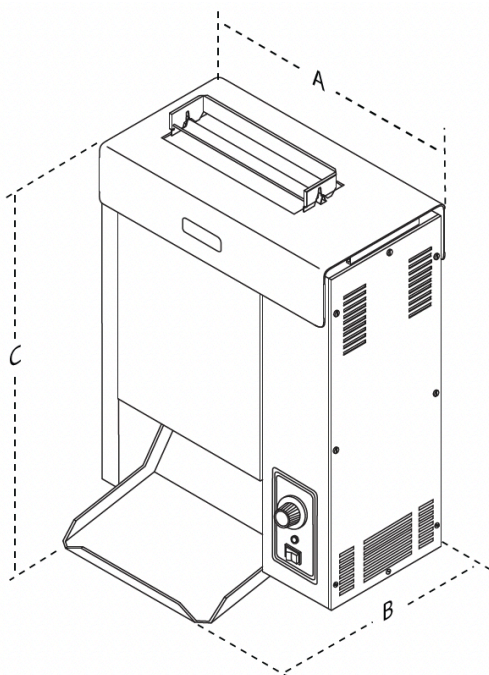

Features:

- Continuously moving conveyor allows for immediate toasting
- Separate compression adjustments for heel and crown
- Release sheets allow buns to move easily down the heated platen without sticking or slipping
- Easy to operate and clean
- Stainless steel construction

VCT-50

Electrical Ratings

Dimensions

Model & Mfg. No.	Capacity*	Approvals	Plug	Volts	Watts	Amps	Hz.	Width (A)	Depth (B)	Height (C)	Shipping Weight
VCT-50 9200600	50-sec. toast time		NEMA 5-15P	120	1760	14.7	50/60	21 1/4" (540 mm)	15 1/4" (387 mm)	23 1/4" (591 mm)	84 lbs. (38.1 kg)
VCT-50 9200606	50-sec. toast time		NEMA 6-20P	208-240	3460	12.5-14.4	50/60	21 1/4" (540 mm)	15 1/4" (387 mm)	23 1/4" (591 mm)	84 lbs. (38.1 kg)
VCT-50 9200602	50-sec. toast time		NEMA 5-20P	120	3460	12.5-14.4	50/60	21 1/4" (540 mm)	15 1/4" (387 mm)	23 1/4" (591 mm)	84 lbs. (38.1 kg)
VCT-50 9200608	50-sec. toast time		CEE 7/7	208-240	2600-3460	12.5-14.4	50/60	22 1/4" (565 mm)	15 1/4" (387 mm)	23 1/4" (591 mm)	84 lbs. (38.1 kg)
VCT-50 9200609	50-sec. toast time		IEC-309	208-240	2600-3460	12.5-14.4	50/60	22 1/4" (565 mm)	15 1/4" (387 mm)	23 1/4" (591 mm)	84 lbs. (38.1 kg)

Dimensions are for item without shipping box. Shipping weight includes item and shipping box. Items highlighted in blue are for international markets.

***Toast time will vary 20% depending on power frequency**

Bun Specifications

Crowns			Heels		
Feeder Opening	Min.	Max.	Feeder Opening	Min.	Max.
1 1/4" (32mm)	1/2" (13 mm)	7/8" (22 mm)	1 1/4" (32 mm)	1/2" (13 mm)	7/8" (22 mm)