



PRODUCT SPECIFICATIONS SHEETS 2 AND 3 GLASS DOORS



VR-35-RE-HC

Height 74.00"
Length 56.00"
Depth 25.75"
Cubic Ft. 35
Liters 991
Bottles (20 oz) . . 404
Cans (12oz) 904



CR-49-HC

Height 78.00"
Length 60.00"
Depth 29.50"
Cubic Ft. 49
Liters 1,388
Bottles (20 oz) . . 620
Cans (12oz) . . . 1,422



CR-65-HC

Height 78.00"
Length 78.00"
Depth 29.50"
Cubic Ft. 65
Liters 1,842
Bottles (20 oz) . . 830
Cans (12oz) . . . 1,926

FEATURES

- Interior and exterior constructed of heavy duty white coated steel
- Stainless steel floor
- Polyurethane insulation with cyclopentane as blowing agent
- Double pane glass door with Low-E protection
- Illuminated top header sign
- Externally mounted hinged glass doors
- Recessed door handle
- Heavy duty shelves with clips
- Heavy duty hinges with self closing mechanism
- Forced air evaporator for rapid temperature "Pull Down"
- Self contained heavy duty 134a condensing unit
- Energy efficient LED lighting
- UL Classified to ANSI/NSF 7



MODEL NO. NUMBER	DESCRIPTION	VOLTAGE	AMPS	TEMP	HP	EST. SHIP WEIGHT
VR-35-RE-HC	2 DOOR/6 SHELVES	115	8.4	32°F - 39°F	1/3	515#
CR-49-HC	2 DOOR/8 SHELVES	115	10.8	32°F - 39°F	1/2	698#
CR-65-HC	3 DOOR/9 SHELVES	115	16.0	32°F - 39°F	3/4	810#

TECHNICAL DATA / 2 AND 3 GLASS DOORS

MODEL #	VR-35-RE-HC	CR-49-HC	CR-65-HC
OUTSIDE DIMENSIONS			
DEPTH	25.75"	29.50"	29.50"
LENGTH	56.00"	60.00"	78.00"
HEIGHT	74.00"	78.00"	78.00"
DOOR SIZE	28.00" X 47.75"	30.00" X 55.75"	25.75" X 55.75"
DOOR TYPE	2 SWING	2 SWING	3 SWING
INSIDE DIMENSIONS			
DEPTH	21.75"	25.25"	25.25"
LENGTH	51.25"	55.25"	73.25"
HEIGHT	54.75"	61.25"	61.25"
SHELF SIZE	(3) 24.50" X 17.875" (3) 26.125" X 17.875"	(8) 27.13" X 21.625"	(8) 22.13" X 22.375" (4) 27.75" X 22.375"
# OF SHELVES	6	8	12
CAPACITY: CUBIC FOOT	35	49	65
SPECIFICATIONS			
OPERATING TEMPERATURE	32°F-39°F	32°F-39°F	32°F-39°F
COMPRESSOR SIZE HP	1/3	1/2	3/4
VOLTAGE	115	115	115
AMPERAGE	8.4	10.8	16.0
CORD AND PLUG	YES	YES	YES
SHIPPING DIMENSIONS			
DEPTH	30.00"	34.00"	34.00"
LENGTH	60.00"	64.00"	82.00"
HEIGHT	80.00"	84.00"	84.00"
GROSS WEIGHT LBS.	515	698	810
CUBIC FEET	83	106	135

TOP VIEWS AND SIDE VIEWS

VR-35-RE-HC

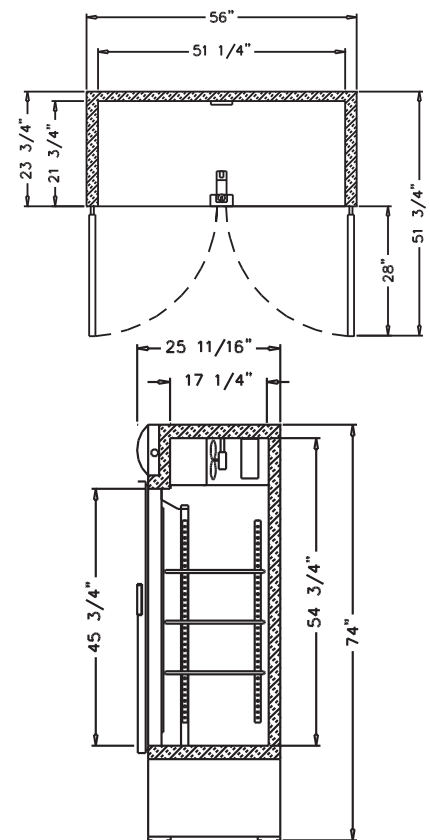

TOP VIEWS AND SIDE VIEW

CR-65-HC

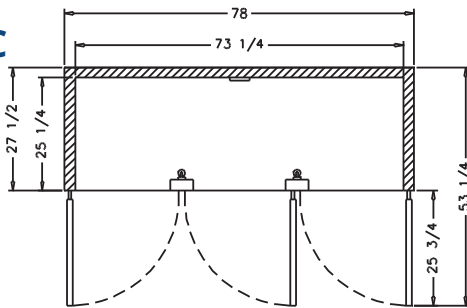

CR-49-HC

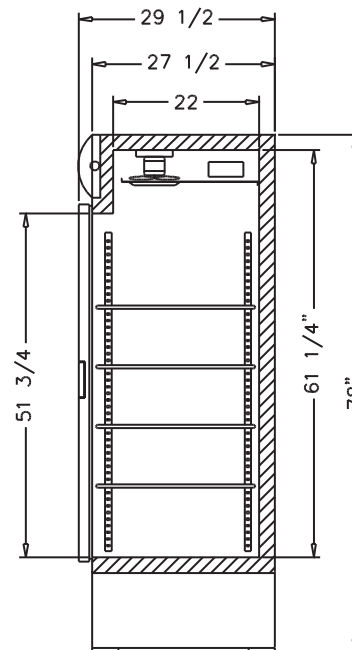
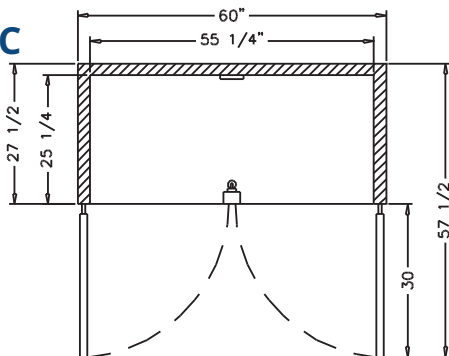

A Division of HMC Enterprises LLC • 831 East Cayuga St • Philadelphia, PA 19124 USA

(215) 464-6800 • 1-800-344-8222 • Fax (215) 969-4890 • E-Mail: sales@howardmccray.com • www.howardmccray.com

