



PRODUCT SPECIFICATIONS SHEETS GLASS DOOR COUNTER TOPS



VR-7-HC

(FORMALLY JUNIOR-1-HC)

Height ...53.8125
Length ...21.0625"
Depth23.50"
Cubic Ft.7
Liters198
Bottles (20oz) ..90
Cans (12oz) ...216



VR-8-HC

(FORMALLY V-252-HC)

Height ...59.0625"
Length ...21.0625"
Depth23.50"
Cubic Ft.8
Liters227
Bottles (20oz) ..120
Cans (12oz) ...252



VR-10.5-HC

Height ...53.4375"
Length25.00"
Depth22.50"
Cubic Ft.9.6
Liters283
Bottles (20oz) ..168
Cans (12oz) ...336



VR-12-HC

Height ..62.5625"
Length25.00"
Depth22.50"
Cubic Ft.12
Liters340
Bottles (20oz) ..210
Cans (12oz) ...432



VR-15-HC

Height65.625"
Length29.875"
Depth26.00"
Cubic Ft.15
Liters425
Bottles (20oz) ..192
Cans (12oz) ...504



- Cases are designed to operate at 75°F and 55% relative humidity.
- Specification subject to change without notice.

FEATURES

- Interior and exterior constructed of heavy duty white coated steel
- Polyurethane insulation with cyclopentane as blowing agent
- Double pane glass door with Low-E protection
- Illuminated top header sign (VR-8-HC)
- Externally mounted hinged glass doors
- Recessed door handle
- Heavy duty shelves with clips
- Heavy duty hinges with self closing mechanism
- Forced air evaporator for rapid temperature "Pull Down"
- Self contained heavy duty 134a condensing unit
- Energy efficient LED lighting
- UL Classified to ANSI/NSF 7



MODEL NO. NUMBER	DESCRIPTION	VOLTAGE	AMPS	TEMP	HP	EST. SHIP WEIGHT
VR-7-HC	1 DOOR/2 SHELVES	115	4.5	32°F - 39°F	1/5	187#
VR-8-HC	1 DOOR/3 SHELVES	115	4.5	32°F - 39°F	1/5	205#
VR-10.5-HC	1 DOOR/3 SHELVES	115	5.2	32°F - 39°F	1/5	230#
VR-12-HC	1 DOOR/3 SHELVES	115	5.2	32°F - 39°F	1/5	235#
VR-15-HC	1 DOOR/3 SHELVES	115	2.6	32°F - 39°F	1/4	310#

A Division of HMC Enterprises LLC • 831 East Cayuga St • Philadelphia, PA 19124 USA

(215) 464-6800 • 1-800-344-8222 • Fax (215) 969-4890 • E-Mail: sales@fogelusa.com • www.fogelusa.com

TECHNICAL DATA / GLASS DOOR COUNTER TOPS

MODEL #	VR-7-HC	VR-8-HC	VR-10.5-HC	VR-12-HC	V-15-HC
OUTSIDE DIMENSIONS					
DEPTH	23.50"	23.50"	22.50"	22.50"	26.00"
LENGTH	21.0625"	21.0625"	25.00"	25.00"	29.875"
HEIGHT	52.8125"	59.0625"	53.4375"	62.5625"	65.625"
DOOR SIZE	21.75" X 42.25"	20.63" X 38.50"	26.25 X 43.00"	25.00" X 52.6875"	30.00" X 47.75"
DOOR TYPE	1 SWING	1 SWING	1 SWING	1 SWING	1 SWING
INSIDE DIMENSIONS					
DEPTH	18"	18"	18.50"	18.50"	21.6875"
LENGTH	17.5625"	17.5625"	21.50"	21.50"	25.25"
HEIGHT	38.6875"	45.3125"	41.4375"	51.00"	45.88"
SHELF SIZE	16.75"X16.75"	16.75"X16.75"	21.25"X17.50"	21.25"X17.50"	24.50"X19.50"
# OF SHELVES	2	3	3	3	3
CAPACITY: CUBIC FOOT	7	8	10	12	15
SPECIFICATIONS					
OPERATING TEMPERATURE	32°F-39°F	32°F-39°F	32°F-39°F	32°F-39°F	32°F-39°F
COMPRESSOR SIZE HP	1/5	1/5	1/5	1/5	1/4
VOLTAGE	115	115	115	115	115
AMPERAGE	2.0	2.2	2.8	2.0	2.8
CORD AND PLUG	YES	YES	YES	YES	YES
SHIPPING DIMENSIONS					
DEPTH	28.00"	28.00"	28.00"	28.00"	30.00"
LENGTH	25.00"	25.00"	30.00"	30.00"	33"
HEIGHT	60.00"	66.0"	60.00"	66.00"	68.00"
GROSS WEIGHT LBS.	187	205	230	235	310
CUBIC FEET	24	26	29	32	35

TOP VIEWS AND SIDE VIEWS

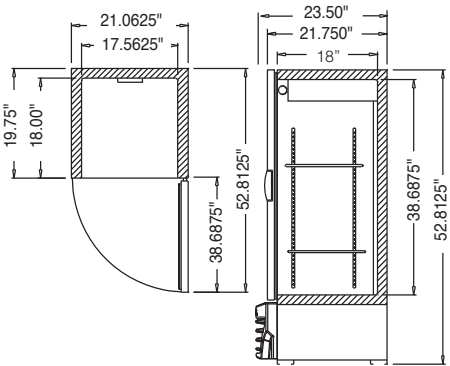

VR-7-HC

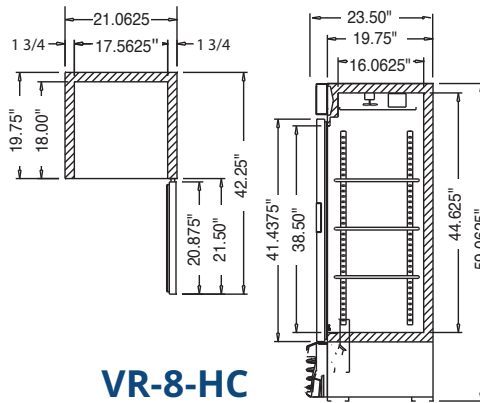

VR-8-HC

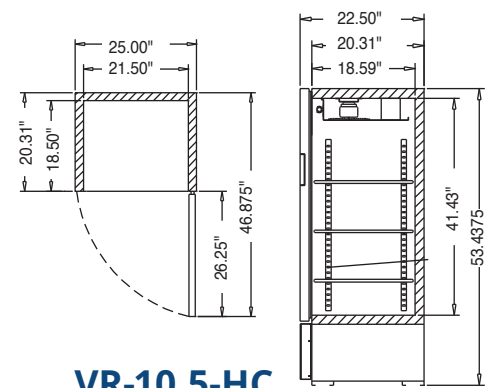

VR-10.5-HC

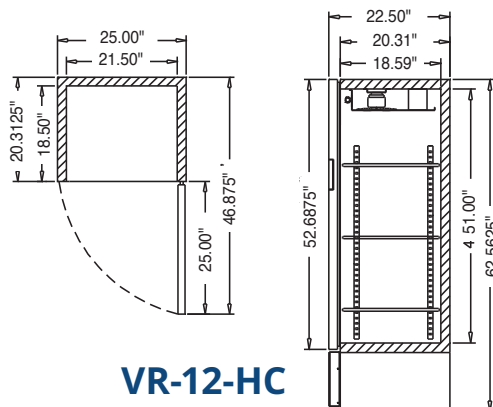

VR-12-HC

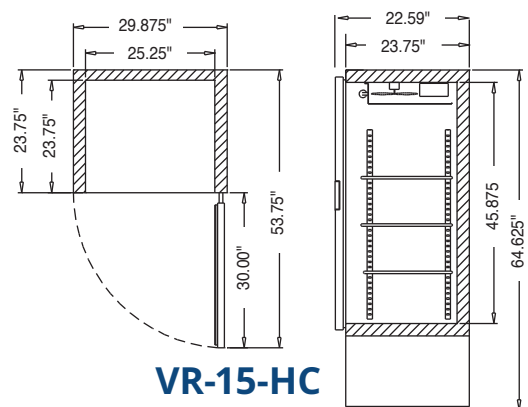

VR-15-HC



A Division of HMC Enterprises LLC • 831 East Cayuga St • Philadelphia, PA 19124 USA

(215) 464-6800 • 1-800-344-8222 • Fax (215) 969-4890 • E-Mail: sales@howardmccray.com • www.howardmccray.com