

Item No.:

Qty.:

Project:

MULTIFRESH® NEXT XXL



The trolley blast chiller with built-in propane refrigeration unit, eco-friendly and completely customizable according to the needs of each professional who chooses the functions, type of performance and features most useful for its use.

The MultiFresh® Next multifunction blast chiller includes up to 12 functions and 150 cycles chosen for you by Irinox to preserve the freshness of the products for longer.

Output *

	Turbo / Turbo Silent
Rapid cooling (from +194°F/+37°F)	220 Lb
Rapid freezing (from +194°F/0°F)	220 Lb

* Tests carried out in compliance with the Irinox procedure using 5-cm thick beef

Capacity

Number of trolleys: 2 x 26" x 20" 1/4 x 69"

Number of trolleys: 2x 28" 1/4 x 18" x 69" 1/4

Can accommodate any manufacture combi rack with dimension < 28" 3/4 x 41" 9/16 x 75" (WxDxH)

Standard construction details

- Refrigeration system equipped with 4 independent natural gas circuits, capable of modulating the power based on the cycle phases.
- R290 coolant gas.
- Combined multi-circuit evaporators, designed by Irinox, treated with cataphoresis to protect against the corrosiveness of foods.
- 5-speed electronic evaporator fans, with working range from 185°F to -40°F.
- Electronic condenser fan with variable speed, to guarantee maximum performance and minimum noise.
- "Scroll" type compressors with high efficiency and low energy consumption.
- Control probes to monitor the correct operation of the four circuits.
- Door opening on the right with hinges on the right.
- New assisted door closing system.
- 5-chamber door seal for high and low working temperatures.
- Tilting seal for an airtight seal between the door and the bottom of the chamber.
- Ergonomic and robust handle made of steel.
- Core probe with 3 detection points with quick screw connector, anti-corrosion, watertight IP67.
- Magnetic flat surface to fix the core probe.
- Upper grille which guarantees a wide passage of air towards the condensers.
- Easy extraction and cleaning of the condenser filter.
- Maximum cleanliness and hygiene thanks to the surfaces with rounded corners inside the cell.
- Internal and external material in AISI 304 stainless steel.
- Built-in air condensation.
- Fitted with a stainless steel ramp.
- Radiused cell bottom for maximum cleanliness and hygiene, with 9/16" internal steel thickness reinforced with 11/16" of marine plywood, insulation thickness varying from 3" 9/16 to 2" 3/8.
- Top of the chamber with 3" 1/8 insulation thickness
- Cell sides with 3" 15/16 insulation thickness.
- Cell back with insulation thickness varying from 5" 5/16 to 3" 1/8.
- Door with 3" 3/8 insulation thickness.
- Condensation drain at the back of the cell.
- Wi-Fi module included for connection to FreshCloud®.
- Sanigen® (Irinox patented sanitization system).

Item No.:

Qty.:

Project:

Operation

2 available configurations:

Essential It is the configuration that includes the best-known functions of the blast chiller: cooling, rapid freezing, cold storage and non-stop cooling/freezing; regardless of the product introduction temperature, it always guarantees excellent results in terms of quality and temperature uniformity in the cell.

Excellence It is the configuration that includes 12 functions. In addition to the cold functions present in the Essential configuration, you will find: hot preservation, defrosting, ready-to-serve, low-temperature cooking, chocolate melting, leavening, pasteurization and drying.

- MultiFresh® Next's cooling cycles lower to 37.4°F the core temperature of the food, introduced at any temperature, even as soon as it is out of the oven, and quickly cross the band of maximum bacterial proliferation, the cause of its natural ageing.
- MultiFresh® Next's freezing cycles transform the water contained in food into microcrystals that preserve its structure and quality for longer.
- Automatic recognition of manual work mode (timed) or automatic mode (with probe).

2 available performance levels

Turbo: this performance guarantees the declared cooling and freezing capacity, thanks to 4 circuits. Excellent performance is guaranteed up to an ambient temperature of 104°F, climate class 5, following the instructions for correct installation.

Turbo Silent: this performance guarantees the cooling and freezing capacity of the Turbo performance, with a very low level of noise emissions, thanks to the use of sound-absorbing material in the refrigeration unit compartment.

Excellent performance is guaranteed up to an ambient temperature of 104°F, climate class 5, following the instructions for correct installation.

Interface

Display 10" with capacitive screen, colour LED bar to follow the progress of the ongoing cycle even from a distance.

Equipped with:

- Acoustic signal with adjustable intensity and fixed tone.
- Dashboard customisable with the customer's most used cycles.
- Ability to customize and/or create new cycles.
- Library with all cycles made by the customer and by Irinox.

Connectivity

FreshCloud® is Irinox's IOT technology that allows you to control and interact with MultiFresh® Next at any time via an APP.

The functions included in the application are:

- Remote monitoring of the cycle in progress: connection status, cell temperature, core temperature, kitchen and machine name, cycle ID in progress, cycle and phase progress.
- Remote parameter modification (ventilation, cabinet temperature, core probe temperature, humidity level, phase duration).
- Personal cycle library management.
- Machine status monitoring: connection status, machine ID, laboratory name, serial number, door status, Sanigen level.
- Push notification system.
- Usage statistics viewing.
- Haccp report download.
- Software update.

Optional

- Sunken floor.
- Remote condensing unit on right hand side.
- Remote condensing unit on left hand side.
- Water condensation.
- Door opening on the left with hinges on the left.
- External bumper rail to protect the door and display.
- 120° door stop.
- 100° magnetic door stop.
- Sous-vide probe.
- Disassembled.
- Ethernet board.
- Horizontal cage (2 packs).

Product warranty

- 2 years, parts and labor.
- 5 years, compressor.

Item No.:

Qty.:

Project:

MULTIFRESH® NEXT XXL - STANDARD VERSION WITH RAMP

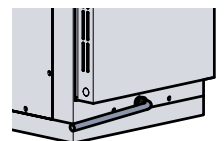
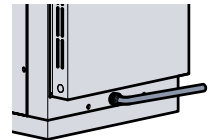
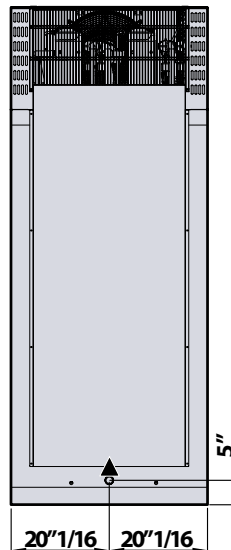
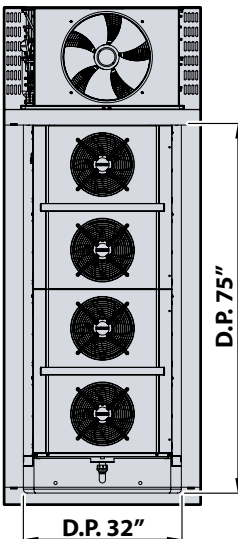
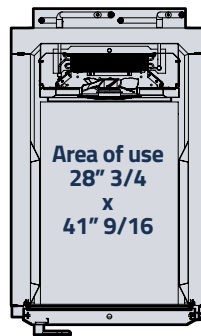
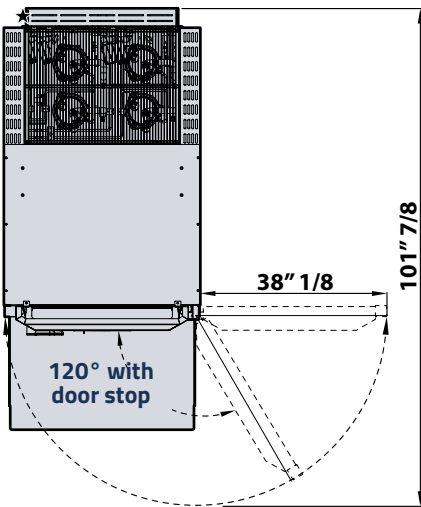
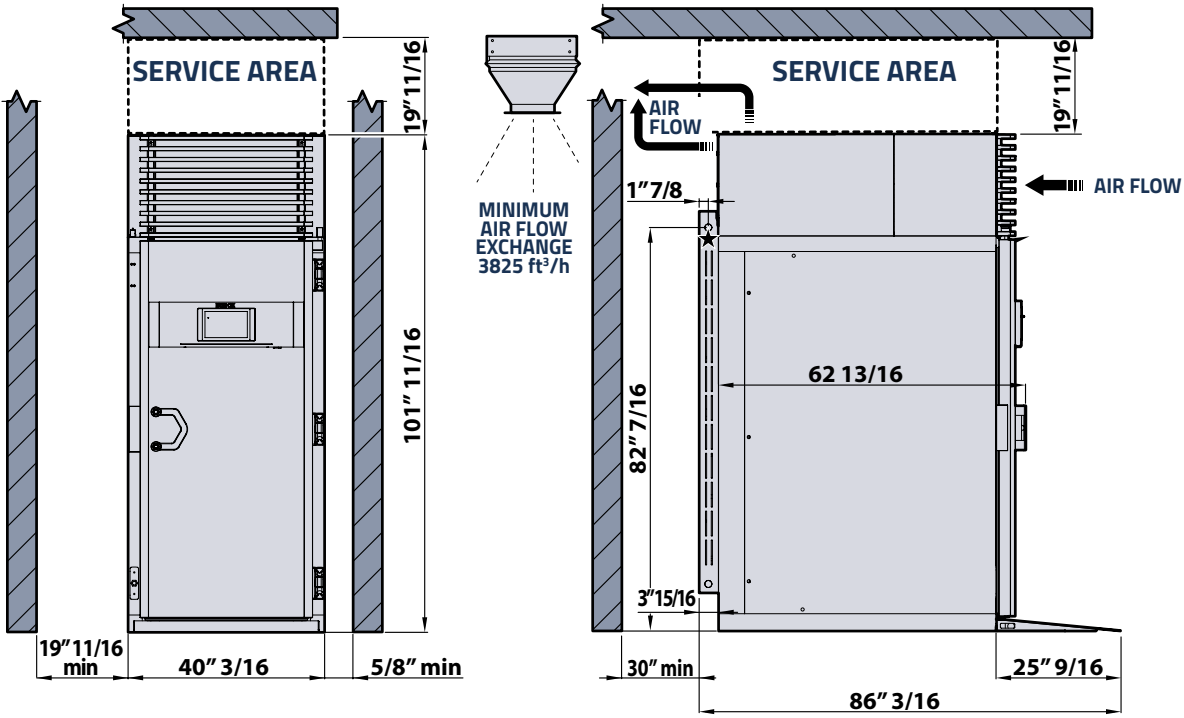

★ Main power cable

▲ Ø 1" 1/4 water drain

Item No.:

Qty.:

Project:

MULTIFRESH® NEXT XXL - SUNKEN FLOOR VERSION

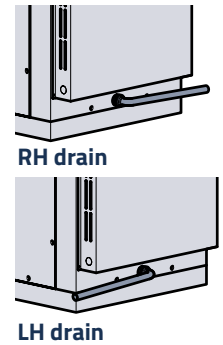
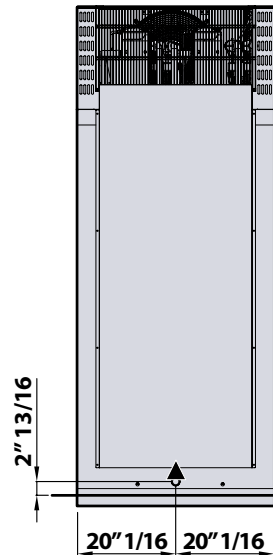
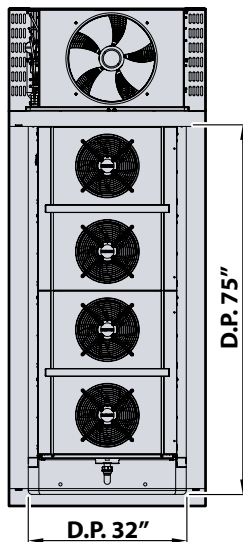
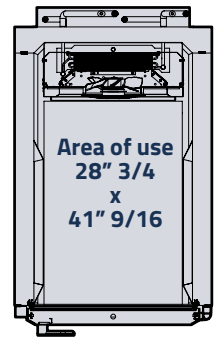
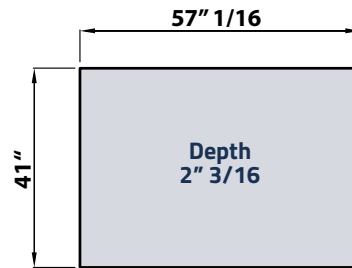
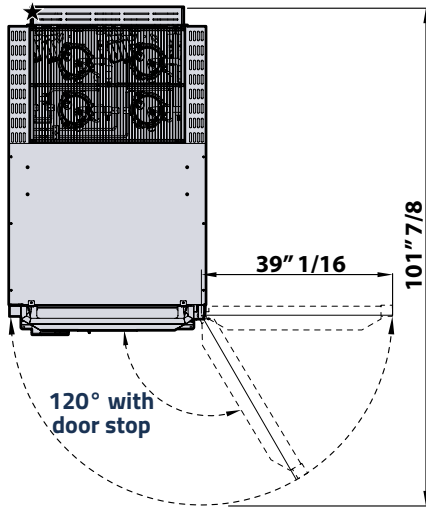
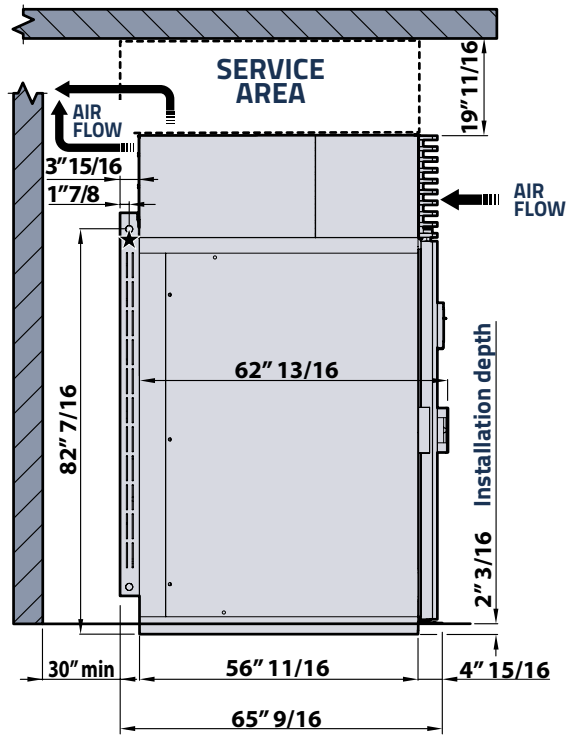
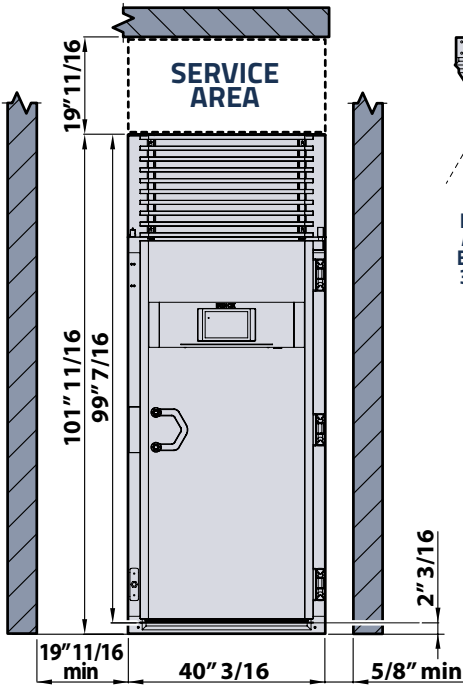

★ Main power cable

▲ Ø 1" 1/4 water drain

Item No.:

Qty.:

Project:

MULTIFRESH® NEXT XXL -VERSION WITH RAMP AND CONDENSING UNIT ON SIDE

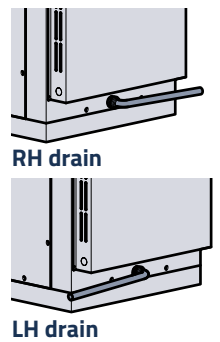
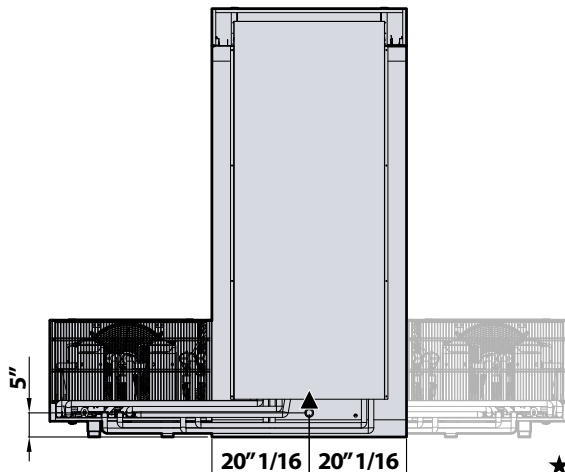
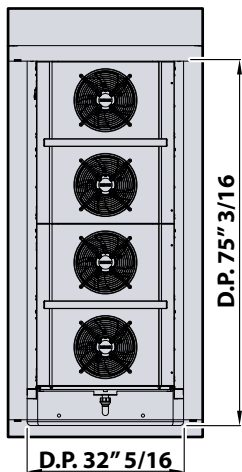
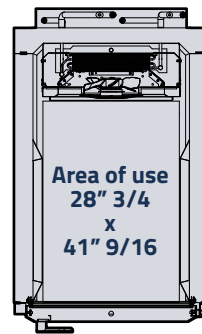
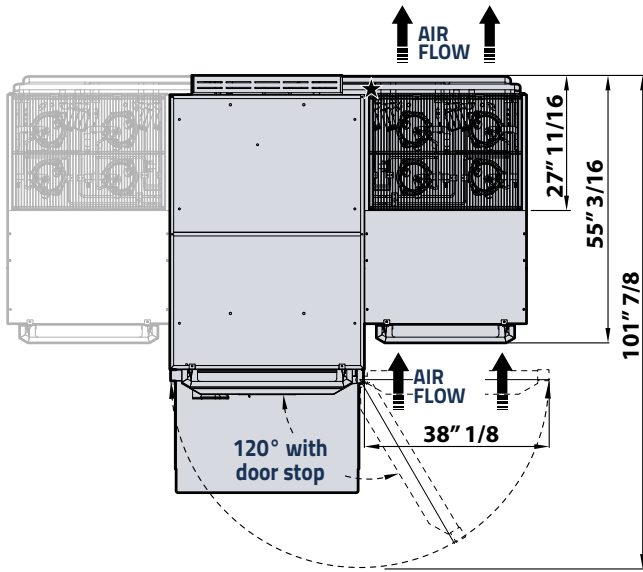
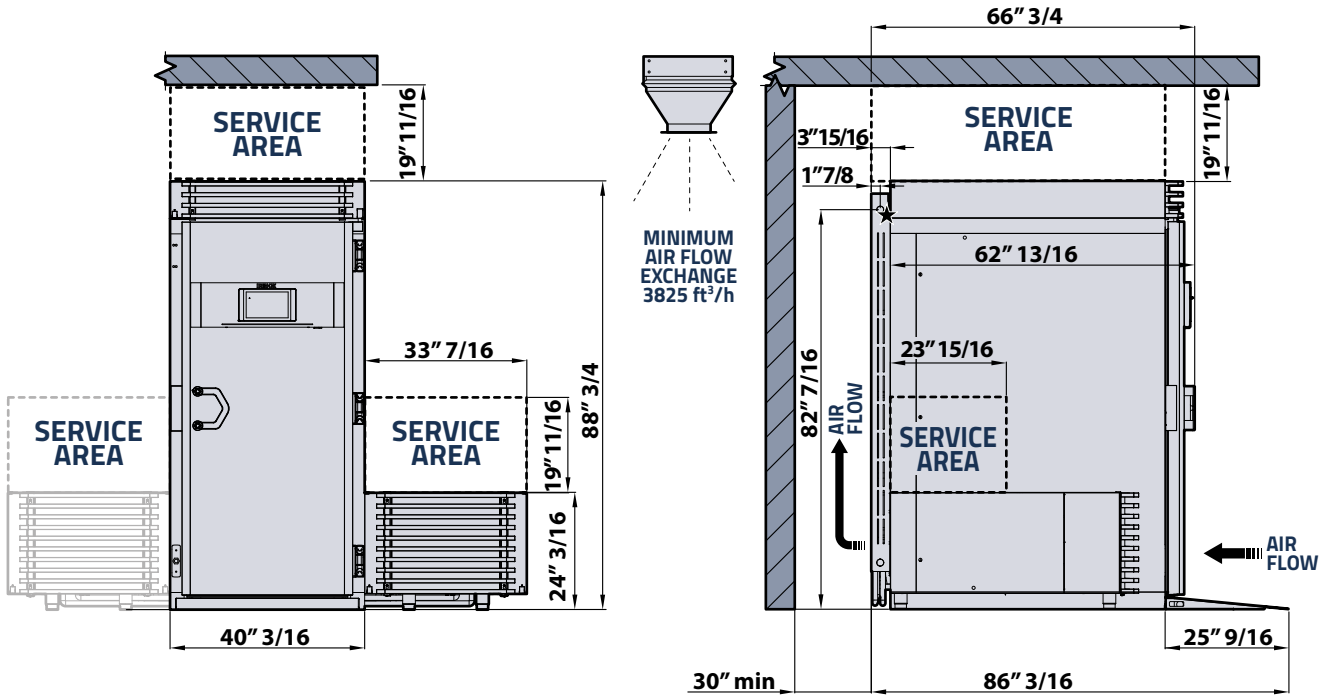

★ Main power cable

▲ Ø 1" 1/4 water drain

Item No.:

Qty.:

Project:

MULTIFRESH® NEXT XXL - SUNKEN FLOOR VERSION AND CONDENSING UNIT ON SIDE

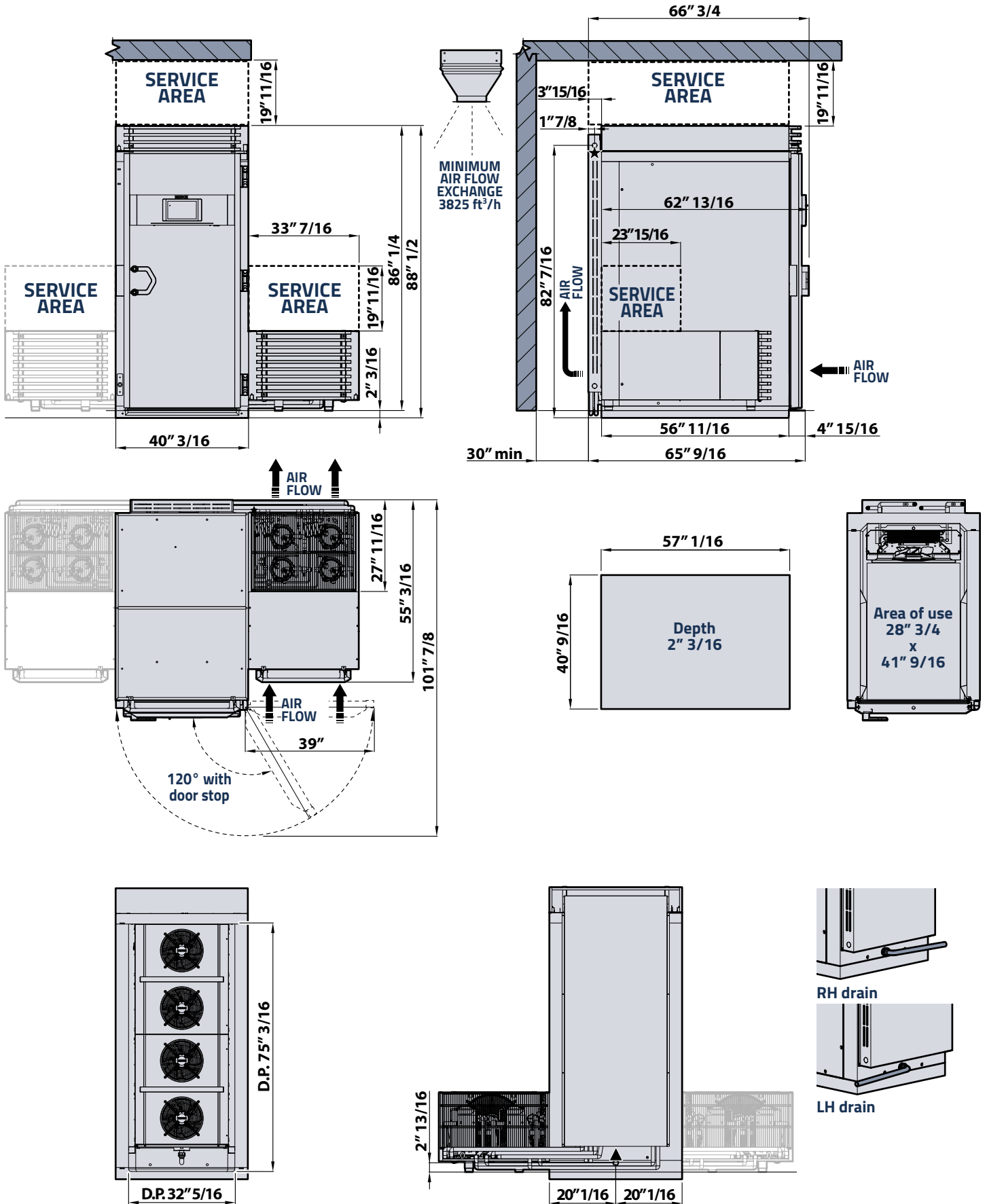

★ Main power cable

▲ Ø 1" 1/4 water drain

Item No.:

Qty.:

Project:

TECHNICAL SPECIFICATIONS

VOLTAGE	-	208V 3ph+PE 60Hz	
CONDENSATION TYPE		AIR CONDENSATION	WATER CONDENSATION
Blast chilling rated power	kW	9.6	9.1
Blast chilling total amps	A	36.6	34.4
Low temp. Cooking rated power	kW	3.6	
Low temp. Cooking total amps	A	13.7	
Minimum circuit amps (MCA)	A	50	
Max overcurrent protection device (MOPD)	A	50	
Main supply cable	AWG	6 AWG/4C	
Compressor power	HP	4 x 1.5	
Cooling capacity	BTU/h	43334	43334
Max condensing power	BTU/h	66195	66195
Min. required air exchange	cfm	3826	-
Inlet/outlet water connection	NPTf	-	1"
Max water consumption (IN temp +86°F / OUT temp +95°C)	gal/min	-	15.4
MIN / MAX water inlet temp. (cooled water)	°F	-	+50 / +72 °C
MIN / MAX water inlet temp. (tower water)	°F	-	+74 / +95 °C
Refrigerant type	-	R290	
Refrigerant charge (not included)	oz	4 x 5.3	4 x 4.23
Max ambient temperature	*F	109	
Internal dimensions (W x D x H)	in	28" 3/4 x 41" 9/16 x H 75" 3/16	
Total weight self contain unit version	Lb	1223	
Cabinet only weight (on side version)	Lb	870	
Condensing unit only weight (on side version)	Lb	353	

INSTALLATION

The blast chiller must be installed following and complying with what is stated in the appropriate installation manual. The contents of the manual must be carefully followed to ensure correct operation and to protect the user's rights under the warranty. Continuous product development may require changes to specifications without notice.

Irinox North America Inc.

9990 NW 14th Street, Suite 107 - Miami, FL 33172 U.S.A.
Tel. +1 786 870 5064 | info@irinnoxnorthamerica.com | www.irinnoxprofessional.com/usa

