

/// Frozen Drink Machine

6690-C

220V - Gravity Feed
Refrigerated Hopper Pre-Chills Mix

- ☆ Single Flavor // Countertop
- ☆ Up to 288, 10oz drinks per hour
- ☆ 7.3 Qt Cylinder - 26.4 Qt Hopper
- ★ Higher capacity solution with greater flexibility to serve larger crowds alcoholic & non-alcoholic frozen drinks including milkshakes



Fast Freeze Down

Patented high efficiency heat exchanger allows fast freeze down with low energy consumption

Reduced Parts - Easy Cleaning

Reduced parts and single piece beater/shaft design improve cleaning time and operational experience

Simple Control, Easy Operation

Simple and intuitive control system makes operation and viscosity adjustment easy, swift and more precise

Low Mix Indicator & Freeze Protection

Light turns "ON" at low mix to alert operator to add mix. Prevents Freeze Ups when mix is out

Refrigerated Hoppers, Standby, and Indicator

Maintains product temperature in mix hopper overnight and improves freeze and recovery time. Indicator lights for standby/night mode.

Safety Protections & Light Box Merchandising

High pressure switch prevents compressor overheating. Thermal overload protects motor and drive train. Illuminated flavor cards to attract more business

Self-closing Dispensing Valve

Automatically prevents product overflow after dispense



★ The Spaceman Difference

QUALITY

Affordable Quality

Designed by Aerospace Engineers

- ✓ Craft quality design, less investment
- ✓ Built to last
- ✓ Luxurious mouthfeel

VALUE

Microcrystal Technology

3X Patented Freezing Speed

- ✓ Superior fast freeze
- ✓ Quick recovery
- ✓ Lowest energy cost per serving

SERVICE

Restriction-Free Service

Service on Your Terms

- ⊘ No binding contracts
- ⊘ No locked-in maintenance fees
- ⊘ No monthly equipment costs

/// Frozen Drink Machine

6690-C

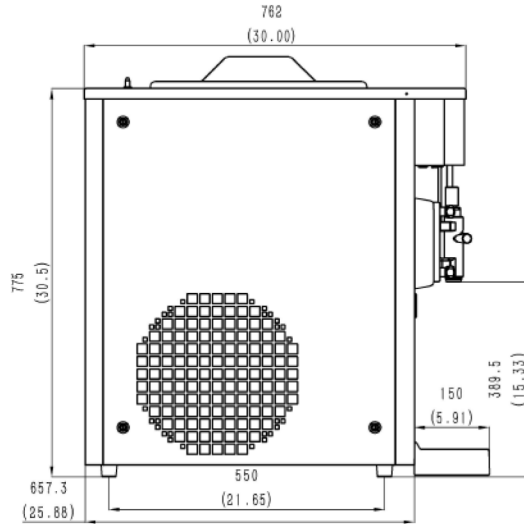
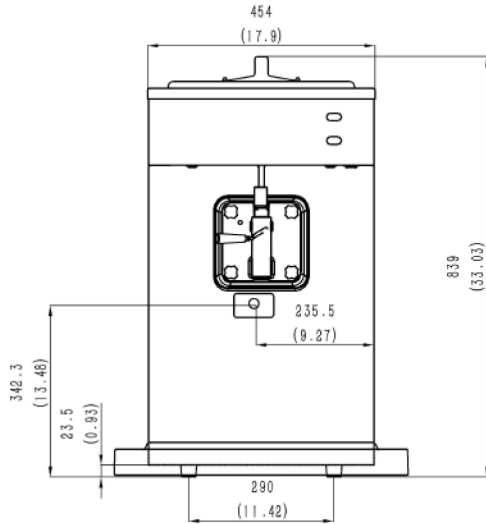

Specifications

Flavors	1
Freezing Cylinders	1 x 6.9L / 7.3 Qt
Mix Hoppers	1 x 25L / 26.4 Qt
Output Capacity (10oz servings)	288 servings/hr
Max Serving Size	32oz
Clearance Requirements	152mm/6"

Weight	Kg/lb
Net	138 / 307
Shipping	151 / 336
Volume	0.51 CBM / 17.87 CBF

Dimensions	Net (mm/in)	Shipping (mm/in)
Width	454 / 17.9	600 / 23.6
Depth	657 / 25.9	860 / 33.9
Height	839 / 33.0	980 / 38.6

Electrical	Plug(NEMA)	MFS	MCA	Power(kW)
220-240/50/1	L6-20	20	13	2.0
208-230/60/1	L6-20	20	15	2.2

Features

Control System	One, Mechanical
Refrigerated Hopper	✓
Hopper Agitator	✓
Standby Mode	✓
Auto Closing Dispensing Valve	✓
Low Mix Indicator Light	✓
Low Mix Indicator Alarm	✓
Standby Mode	✓
Standby Indicator Light	✓
High Pressure Protection	✓
Thermal Overload Protection	✓

Available Options

Top Air Discharge Chute	✓
Spinner	✓
Light Box	✓

*Above specifications are subject to change without notice