



Your Solutions Partner

# Specifications

F.O.B. Sedalia, Missouri 65301



**DBC-2E**

## Approval Stamp(s):

### PRODUCT INFORMATION:

PROJECT: \_\_\_\_\_

ITEM: \_\_\_\_\_

QUANTITY: \_\_\_\_\_

### MODEL:

Duke Baking Centers - DBC-2E  
Full Size - Deep Depth - Electric

- DBC-2E      613-E3 Oven, Electric/  
PFB-2 Proofer Base

### OVEN SECTION:

- 6 racks/13 rack positions
- Porcelain interior finish - 29"W x 24"H x 28" D cavity
- Stainless steel front, sides, top
- 65/35 stainless steel dependent doors
- Double pane glass in 65 door
- 1-1/2" insulation on bottom , sides, back
- 3" insulation on top

### OVEN CONTROLS:

- "XX" - Solid state digital time and temperature controls, 12-hour countdown timer, Cook and Hold feature, 2-speed fan, Pulse fan capability

### PROOFER SECTION:

- Stainless steel front, sides, back and top
- Tempered glass on self-closing door
- Stainless steel cavity - 8 rack guides/16 racks
- Solid state temperature control
- 1-hour electric dial timer
- Water reservoir

### AGENCY LISTINGS:



DUKE MANUFACTURING CO.

2305 N. Broadway

St. Louis, MO 63102

800.735.3853 Toll Free

314.231.5074 Fax

www.dukemfg.com

SS-1039 Proofer Base-2 DBC-2 Electric

Specification subject to change



DUKE BAKING CENTERS -DBC-2 - ELECTRIC

Catalog No. DBC-DBC2E

A.I.A. File No. 35-C-13

REV C 09/25/2019

# DUKE BAKING CENTERS - DBC-2E

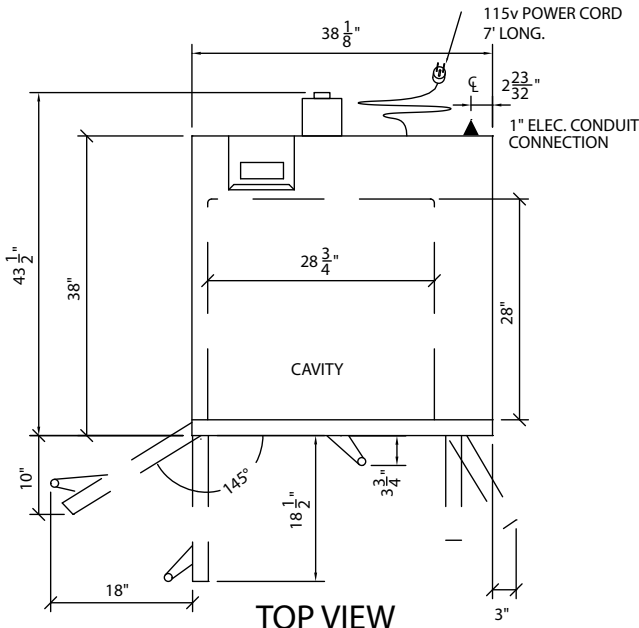

Electrical Specifications			
	208 Volts	240 Volts	KW
1 Phase	40.0 Amps	35.0 Amps	10.0
3 Phase	30.5 Amps	21.0 Amps	10.0
PFB-2	120 Volts		
1 Phase	13.0 Amps	n/a	1.5
▲ - Electronic connection point			

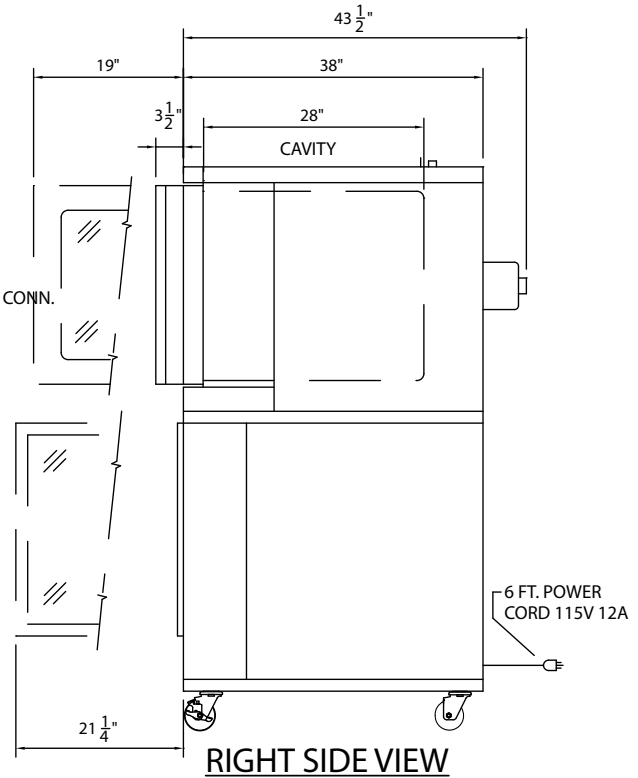
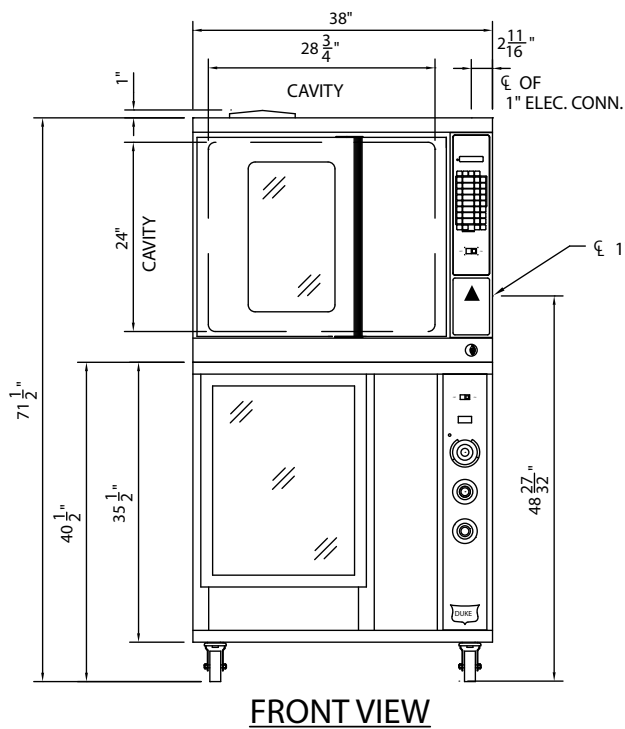

**DIMENSIONS:**

**FREIGHT CLASS: 85**

Model	Depth		Width		Height		Cube ft. crated	Weight	
	in	cm	in.	cm	in.	cm		lbs	kg
613-E3	43-1/2	110.5	38	96.5	31-1/2	80.0	35.3	540	245
PFB-2	38	96.5	38	96.5	40-1/2	102.9	39.4	300	136



**Duke Manufacturing Co.**  
 2305 N. Broadway  
 St. Louis, MO 63102

Phone: 314-231-1130  
 Toll Free: 1-800-735-3853  
 Fax: 314-231-5074

www.dukemfg.com



Your Solutions Partner

# Specifications

F.O.B. Sedalia, Missouri 65301



DBC-2G

### AGENCY LISTINGS:

613-G3



### PROOFER



DUKE MANUFACTURING CO.

2305 N. Broadway

St. Louis, MO 63102

800.735.3853 Toll Free

314.231.5074 Fax

www.dukemfg.com

SS-1043 Proofer Base-2 DBC-2 Gas

### Approval Stamp(s):

#### PRODUCT INFORMATION:

PROJECT: \_\_\_\_\_

ITEM: \_\_\_\_\_

QUANTITY: \_\_\_\_\_

#### MODEL:

Duke Baking Centers - DBC-2G

Full Size - Deep Depth - Gas

- DBC-2G                      613-G3 Oven, Gas/PFB-2 Proofer Base

#### OVEN SECTION:

- 6 races/13 rack positions
- Porcelain interior finish - 29"W x 24"H x 28" D cavity
- Stainless steel front, sides, top
- Double pane glass in 65 door
- 1-1/2" insulation on bottom , sides, back/3" on top
- 46,000 BTU

#### OVEN CONTROLS:

- "XX" - Solid state digital time and temperature controls, 12-hour countdown timer, Cook and Hold feature, 2-speed fan, Pulse fan capability

#### PROOFER SECTION:

- Stainless steel front, sides, back and top
- Tempered glass on self-closing door
- Stainless steel cavity - 8 rack guides/16 racks
- Solid state temperature control
- 1-hour electric dial timer
- Water reservoir

Specification subject to change



# DUKE BAKING CENTERS - DBC-2G FULL SIZE - DEEP DEPTH - GAS

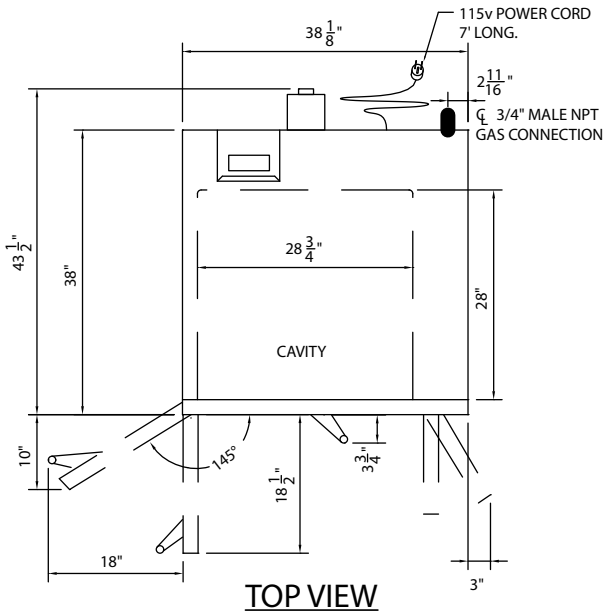

TOP VIEW

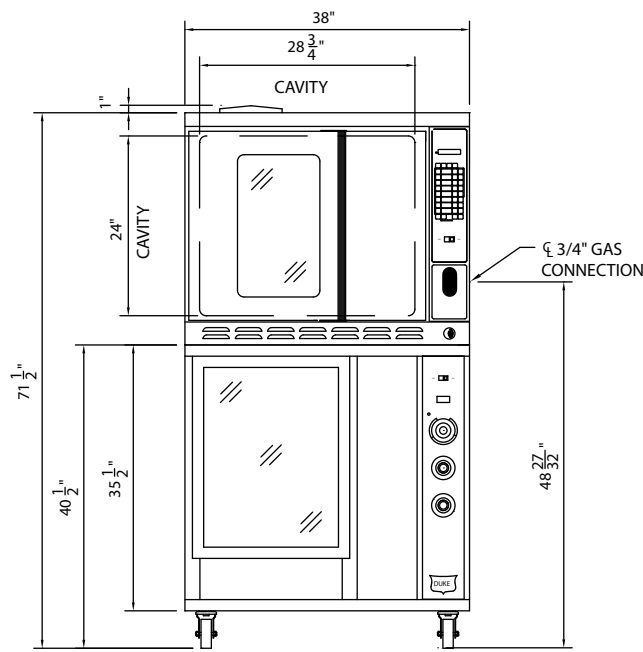

FRONT VIEW

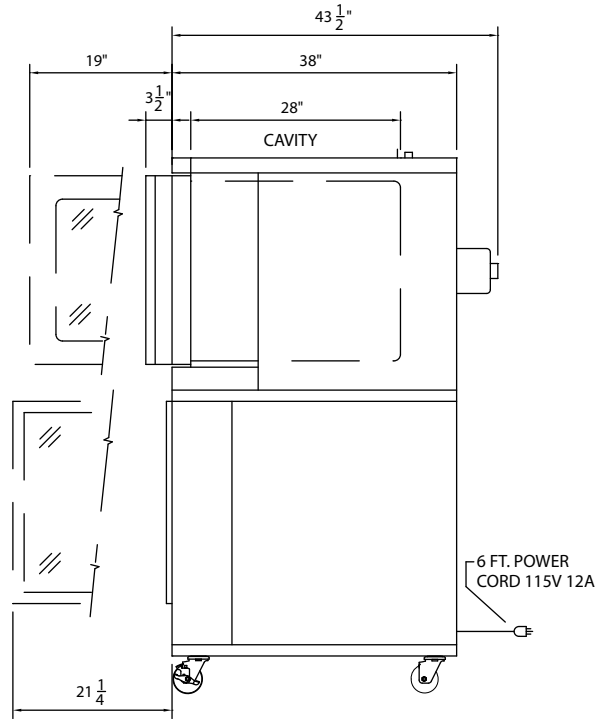

RIGHT SIDE VIEW

Gas Specifications		
<b>613-G3</b>	BTU/Hour	46,000
Regulated gas pressure required 3.5"WC natural /10"WC propane		
Combustible surface clearance - 1" side, 1" rear, 6" floor		
■ - Gas connection		
3/4" Gas connection		
Electrical requirements: 3.5 Amps/ 115V		
Standard 115V units supplied with 5' cord and plug		
<b>PFB-2</b>	120V	1 Phase - 13.0 Amps 1.5 KW

**DIMENSIONS:**

**FREIGHT CLASS: 85**

Model	Depth		Width		Height		Cube ft. crated	Weight	
	in	cm	in.	cm	in.	cm		lbs	kg
613-G3	43-1/2	110.5	38	96.5	31-1/2	80.0	35.3	505	229.1
PFB-2	38	96.5	38	96.5	40-1/2	102.9	39.4	210	95.3

Specify gas type

Specify altitude over 2000 feet



**Duke Manufacturing Co.**  
2305 N. Broadway  
St. Louis, MO 63102

Phone: 314-231-1130  
Toll Free: 1-800-735-3853  
Fax: 314-231-5074

www.dukemfg.com