

Project _____
 Item _____
 Quantity _____
 CSI Section 11400
 Approved _____
 Date _____

Master Gas Convection Oven easyTouch® Control

Master Gas Convection Oven / easyTouch® Control

Models

- MCO-GS-10M
- MCO-GS-20M
- MCO-GD-10M
- MCO-GD-20M



Model MCO-GS-10M

Standard Features

- EasyTouch® screen design with simple on/off switch and intuitive Press and Go interface
- Master 4.3" Controller with 150°F (66°C) to 500° (260°C) temperature range
- Cook'n'Hold
- Direct spark with 100% safety shut off
- 2-speed fan control (high & low) with .6
- HP fan motor
- Total of 60,000 BTU (17.6 kW) loading per oven cavity
- Natural or propane gas
- Stainless steel front, sides, top, and legs
- 60/40 dependent door design with double pane thermal window in both doors and interior lighting
- Full Length, stainless steel positive door closure
- Patented "Safety Door System"
- Porcelain enameled oven interior with coved corners
- 24" cooking cavity height w/6 chrome-plated oven racks on 13-position rack guides
- Double deck models available, suffix -20M
- Deep depth models available, prefix MCO-GD

Warranty

- 2-year limited part & 1 year labor warranty (USA & Canada only)
- 2-year limited part & labor warranty (USA Kindergarten to grade 12 schools only)
- 5 year limited door warranty, excluding window (USA & Canada only)

Options & Accessories

- 80,000 BTU (23.4kW) burner package (natural gas)
- Stainless steel solid door or doors (specify) – No Charge
- Removable stainless steel drip pan
- Deck Fasteners
- Extra oven racks
- Swivel casters, (4) w/front brakes
- 4 Low profile casters, w/front brakes (double ovens only)
- Stainless steel open base with rack guides and shelf
- Direct connect vent
- Back enclosure (stainless steel)
- 3/4" gas flex hose & quick disconnect
- 208 or 240 volt, single phase motor (please specify)
- 50 cycle components
- Maximum security package available, contact factory for details

Specifications

Garland Master Full-Size Standard Depth, prefix MCO-GS or Deep Depth, prefix MCO-GD, gas convection oven.

UL, CUL Gas-Fired and NSF Listed.

60,000 BTU (17.6 kW)/cavity, .6 HP fan motor with two speed fan control. Electronic spark ignition. Natural or propane gas.

EasyTouch™ screen.

Porcelain enameled oven interior with coved corners, Six (6) oven racks and 13-position rack guides.

All model interiors are 29" (736mm) W by 24" (610mm) H, depth is 24" (610mm) for standard depth and 28" (711mm) for deep depth.

Stainless steel front, sides, top, and legs.

60/40 dependent door design with double

pane thermal window in both doors and interior lighting.

Models with suffix -20M are double deck units. Specify voltage if other than 115 volt, 60 Hz, 1 phase.



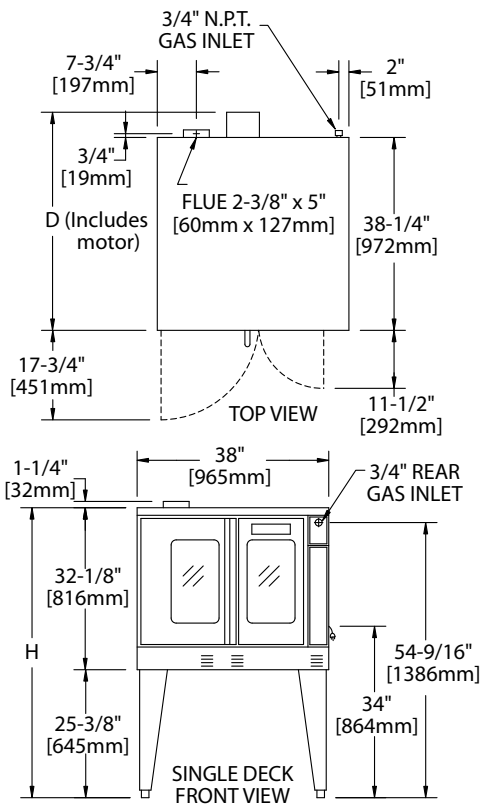

INSTALLATION NOTE:

Combustible Wall Clearances:

Sides: 1" (25mm) Back: 3" (76mm)

*Note: Installations beside units with high heat sources it is recommended to leave 6" (152mm) on the right side of oven. Refer to the installation manual for more details.

Combustible Wall Clearances:

Crated: 47" (1194mm) Uncrated: 32 1/2" (826mm)

Manifold Operating Pressure:

Natural: 4.5" WC (11 mbar) Propane: 10" WC (25 mbar) Max 13.8" WC @ 70°F

Note: Data applies only to North America

PLEASE NOTE:

Standard electrical specifications include motor requirements. (120V units) 115V, .6 HP, 2-speed motor; 1140 and 1725 rpm, 60Hz. (240V units) 200-240V, .6 HP, 2-speed motor; 1140 and 1725 rpm, 60 Hz. A 6 ft. line cord is provided for each 120V deck with a (NEMA #5-15P) plug.

Gas Input Ratings shown here are for installations up to 2,000 ft. (610m) above sea level. Specify altitudes over 2,000 ft. Please specify gas type when ordering.

SINGLE-DECK MODELS	INT. DIMENSIONS: In mm			EXT. DIMENSIONS: In mm			SHIP WT.	SHIP DIM.
	W	H	D	W	H *	D	lbs/kg	cubic Ft.
Standard Depth	29 (736)	24 (610)	24 (610)	38 (965)	57-1/2 (1461)	41-1/4(1048)	515/230	64
Deep Depth	29 (736)	24 (610)	28 (711)	38 (965)	57-1/2 (1461)	44-1/2(1130)	545/245	64

DOUBLE-DECK MODELS	INT. DIMENSIONS: In mm			EXT. DIMENSIONS In mm			SHIP WT.	SHIP DIM.
	W	H	D	W	H *	D	2@lbs/kg	Cubic Ft.
Standard Depth	29 (736)	24 (610)	24 (610)	38 (965)	70-1/2 (1791)	41-1/4(1048)	1030/465	128
Deep Depth	29 (736)	24 (610)	28 (711)	38 (965)	70-1/2 (1791)	44-1/2(1130)	1090/490	128

*Height with or without standard casters. Height with low profile casters (double deck) is 68-1/2" (1740mm).

MODELS	INPUT RATINGS, NAT & PRO			ELECTRICAL SPECIFICATIONS	
	BTU/hr	kW Eqiv.	Gas inlet	120V/1Ph.	240V/1Ph.
Single Deck	60,000	17.6	(1)@3/4" NPT	(1)@9.8A	(1)@5.2A
Double Deck	120,000	35.2	(1)@1" NPT	(2)@9.8A	(2)@5.2A

Garland reserves the right to make changes to the design or specifications without prior notice.