



PRODUCT SPECIFICATIONS SHEETS VERTICAL BEER FROSTERS



FROSTER-B-280-HC

Height..... 79.00"
Length 28.25"
Depth 27.75"



FROSTER-B-18-HC

Height..... 79.00"
Length 28.25"
Depth 27.25"



FROSTER-B-30-HC

Height..... 79.00"
Length 43.50"
Depth 25.88"

FEATURES

- Thermoformed illuminated header
- Electronic thermostat with digital thermometer to show consumer the temperature inside the cabinet
- Heavy duty hinges with self closing mechanism
- Recessed door handle
- Full color decals to attract consumers at the point of sale
- Modern high impact plastic front grill
- Curved foamed-in-place door made of galvanized steel (FROSTER 280)
- UL Classified to ANSI/NSF 7
- Self contained heavy duty R290 condensing unit



MODEL NO. NUMBER	DESCRIPTION	VOLTAGE	AMPS	TEMP	HP	EST. SHIP WEIGHT
FROSTER-B-280-HC	1 DOOR/4 SHELVES	115V/60HZ/1	6.5	25°F - 39°F	1/3	235#
FROSTER-B-18-HC	1 DR GLASS/4 SHELVES	115V/60HZ/1	7.5	25°F - 39°F	1/3	315#
FROSTER-B-30-HC	2 DR GLASS/8 SHELVES	115V/60HZ/1	10.4	25°F - 39°F	2 X 1/4	535#

A Division of HMC Enterprises LLC • 831 East Cayuga St • Philadelphia, PA 19124 USA

(215) 464-6800 • 1-800-344-8222 • Fax (215) 969-4890 • E-Mail: sales@fogelusa.com • www.fogelusa.com

TECHNICAL DATA / VERTICAL BEER FROSTERS

MODEL #	FROSTER-B-280-HC	FROSTER-B-18-HC	FROSTER-B-30-HC
OUTSIDE DIMENSIONS			
DEPTH	27.75"	27.75"	25.885"
LENGTH	28.25"	28.25"	43.50"
HEIGHT	79"	79"	79"
DOOR SIZE	29.375" X 55.5"	29.375" X 55.5"	29.375" X 55.5"
DOOR TYPE	1 SOLID SWING	1 STRAIGHT GLASS SWING	2 STRAIGHT GLASS SWING
INSIDE DIMENSIONS			
DEPTH	21.75"	21.75"	21.75"
LENGTH	23.5"	23.5"	38.75"
HEIGHT	61.5"	61.5"	61.5"
SHELF SIZE	23" X 19.5"	23" X 19.5"	23" X 19.5"
# OF SHELVES	4	4	8
# OF 12OZ. BOTTLES	280	280	490
CAPACITY: CUBIC FOOT	18	18	30
SPECIFICATIONS			
OPERATING TEMPERATURE	23°F-39°F	25°F-39°F	25°F-39°F
COMPRESSOR SIZE HP	1/3	1/3	2 X 1/4
DEFROST	3 @ 30 MIN.	3 @ 30 MIN.	3 @ 30 MIN.
VOLTAGE	115V/60HZ/1	115V/60HZ/1	115V/60HZ/1
AMPERAGE	6.5	7.5	10.4
CORD AND PLUG	YES	YES	YES
SHIPPING DIMENSIONS			
DEPTH	32.00"	32.00"	32.00"
LENGTH	33"	33"	53"
HEIGHT	88"	88"	88"
GROSS WEIGHT LBS.	235	315	535
CUBIC FEET	54	54	108

FROSTER-280-HC

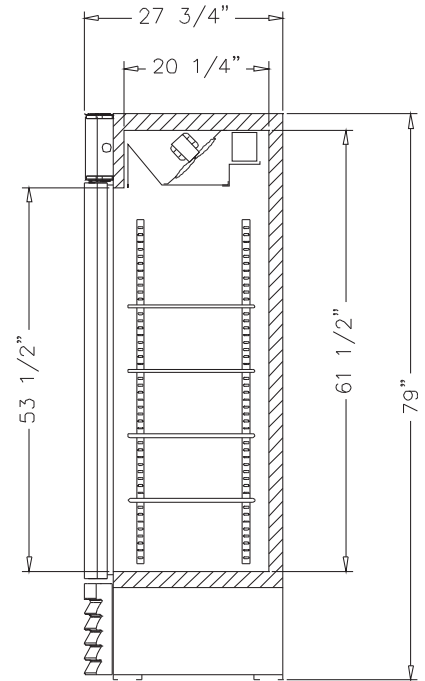

SIDE VIEW



A Division of HMC Enterprises LLC • 831 East Cayuga St • Philadelphia, PA 19124 USA

(215) 464-6800 • 1-800-344-8222 • Fax (215) 969-4890 • E-Mail: sales@howardmccray.com • www.howardmccray.com