



ELECTRIC COUNTER STEAMER

Auto Fill, Manual Drain



SXN-4M



SXN-4M

OPERATION SHALL BE BY:

Electrically heated, boiler free steam generation rated at:

10 kW for Model SXN-4M

The steam generator shall be equipped for operation on:

- 208 VAC, 3 Phase, 50/60 Hz *
- 240 VAC, 3 Phase, 50/60 Hz *
- 220 VAC, 3 Phase, 50/60 Hz *

*** UNIT SHALL BE FIELD CONVERTIBLE TO SINGLE PHASE**

STANDARD FEATURES:

- Water Treatment System
- Automatic water fill system, manual drain system
- 304 stainless steel exterior
- 316 stainless steel cooking chamber with coved corners
- Heavy gauge stainless steel door with full perimeter gasket
- Positive lock and seal mechanism with spring release door
- On/Off power switch
- Ready indicator light
- Cooking indicator light
- 60 minute electromechanical timer with end of cycle audible alarm
- Removable stainless steel pan supports
- Electromechanical controls
- 4" adjustable legs
- Water supply in "Y" strainer (condenser feed)
- Drain tempering system for 140 degree temperature requirement (requires 1/2" cold water connection)

OPTIONS & ACCESSORIES AT ADDITIONAL COST

- | | |
|--|--|
| <input type="checkbox"/> 380 VAC, 3 phase, 50/60 Hz | <input type="checkbox"/> Constant steam feature |
| <input type="checkbox"/> 415 VAC, 3 phase, 50/60 Hz | <input type="checkbox"/> 120 minute timer |
| <input type="checkbox"/> 380/220 VAC, 3 Phase, 50/60 Hz 4 wire | <input type="checkbox"/> Drain hose kit |
| <input type="checkbox"/> 415/240 VAC, 3 Phase, 50/60 Hz 4 wire | <input type="checkbox"/> 28" high single unit stand |
| <input type="checkbox"/> Correctional package | <input type="checkbox"/> 23" high double unit stacking stand |

STANDARD CONSTRUCTION SPECIFICATIONS

Shall be a Crown model **SXN-4M (4 pan)** counter convection steamer with electric steam generator, c-CSA-us and NSF certified.

The steamer shall be constructed of #4 finish stainless steel type 304, with a cooking chamber of one piece all welded type 316 stainless steel with coved corners.

The door shall have a removable inner liner of stainless steel with full perimeter gasket seal, an outer liner of one piece all welded stainless steel, and a positive lock and seal mechanism.

The steamer shall be provided with removable stainless steel pan supports and 4" leveling legs.

The control housing shall be constructed of stainless steel with full access removable panel.

The controls shall include an illuminated power switch, a pilot ready light, a pilot cook light, "60" minute electric timer which sounds an audible sound at the end of the cooking cycle.

Steam flow to the cooking chamber shall be interrupted when the door is opened and shall be reactivated when door is closed.

Standard features include a de-liming port located at the rear of the unit for easy access to allow cleaning of the generator tank, manual blow-down valve, solid state liquid level controls and split water connections for simple hook up to a water treatment system (included).

NOTE: DRAIN PAN PROVIDED BY OTHERS.

SEE REVERSE SIDE OF SPEC SHEET FOR WATER TREATMENT SYSTEM STATEMENTS



Approval Notes: _____

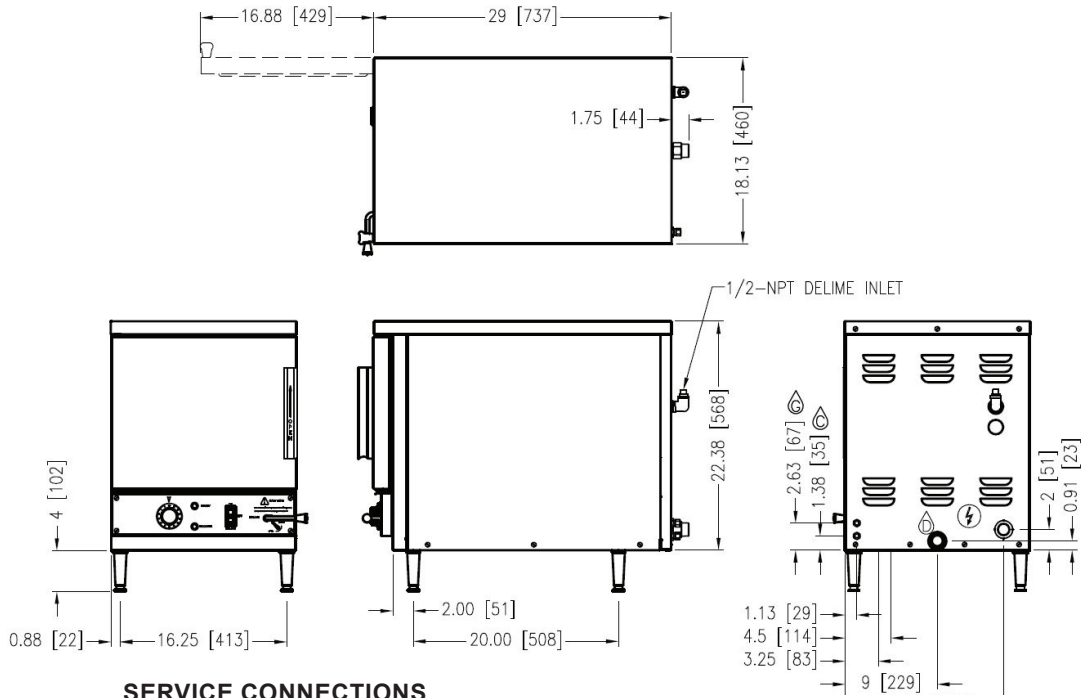

SERVICE CONNECTIONS

- ⚡ – ELECTRICAL CONNECTION: ø 1 1/8" hole for electrical connection. Rating to be as specified on data plate.
- Ⓜ – GENERATOR WATER: 3/8" (10 mm) O.D. tubing at 25-50 psi (170-345 kPa).
- Ⓛ – COLD WATER: 3/8" (10 mm) O.D. tubing at 25-50 psi (170-345 kPa).
- Ⓧ – DRAIN: 1" (13 mm) NPT

ELECTRICAL CHARACTERISTICS

MODEL	kW	AMPS/PHASE							
		208V		220V		240V		380V 8.4kW	415V
		1 PH	3 PH	1 PH	3 PH	1 PH	3 PH	3 PH	3 PH
SXN-4M	9	48.1	27.8	38.2	22.1	41.7	24.1	12.8	13.9

COMPARTMENT PAN CAPACITY, WEIGHT AND CLEARANCE

MODEL	PAN DEPTH	INCHES	1"	2.5"	4"	6"	SHIPPING WEIGHT	MINIMUM CLEARANCE	
		MM	25	64	102	152			
SXN-4M	Total Quantity of Pans		8	4	2	2	155 lbs. [70 kg]	SIDES	0
								BACK	0

WATER QUALITY STATEMENT

Water is the essential ingredient in steam equipment, water quality is the major factor affecting the performance of your appliance. Crown Steam Group offers a Comprehensive Water Treatment System which exceeds our minimum water requirements. Proof of installation and proper cartridges replacement is required for warranty coverage. Water supply to Crown Steam Group steamers must be within these guidelines.

Total dissolved solids.....	Less than 60 PPM	Chlorine	Less than 1.5 PPM
Total alkalinity	Less than 20 PPM	pH Factor	6.8 - 7.3
Silica.....	Less than 13 PPM		

Water which does not meet these standards should be treated with the installation of Middleby's Water Treatment System. Call 919-762-1000 if you have questions concerning your water meeting these parameters.

*Failure or malfunction of this appliance due to poor water quality is not covered under warranty.
Reference www.crownsteamgroup.com for complete warranty details and instructions.

DISCLAIMER

Terry System Cartridge Changes / Installation – "2-3 gallons of water **MUST** be purged at each cartridge change or new installation prior to water supply being fed to the steamer. Failure to do so can result in component damage within the steamer which is not covered under warranty. For additional guidance on proper installation, refer to install documentation provided with each Terry System and Replacement Cartridge Set."

**INTENDED FOR COMMERCIAL USE ONLY.
 NOT FOR HOUSEHOLD USE.**

