

Project:

Item Number:

Quantity:

4-Quart Drop-In Induction Soup Rethermalizers



DESCRIPTION

4-quart Drop-In Induction Rethermalizers use innovative technology to run dry (without water) to improve food quality and minimize waste, while using a fraction of the energy. They ship with an induction-ready inset and improved ergonomic cover so they are ready to use upon arrival. This smaller version of our 7 & 11 qt round induction units gives you an option to expand your product offering with sauces, soups, and other items available in smaller quantities.

PERFORMANCE CRITERIA

Vollrath® Countertop Induction Rethermalizers are designed to take a container of cooked food from a chilled state (below 40.0 °F [4.4 °C]) through the HACCP “danger zone” of 165 °F [73.9 °C] in less than 90 minutes. The performance standard is measured using the NSF mixture chilled to 35 °F (1.7 °C). The electric unit will raise the temperature of this product above 165 °F (73.9 °C) in less than 90 minutes. The temperature will be maintained above 150 °F (65.6 °C) when the food product and pan or inset are used with a standard pan or inset cover, and the food product is stirred regularly.

PERFORMANCE CRITERIA
AGENCY LISTINGS



CAN ICES-001/
NMB-001

This device
complies with
Part 18 FCC
Rules

WARRANTY

All models shown come with a Vollrath® standard warranty against defects in materials and workmanship. For warranty period, exclusions, and details, visit vollrathfoodservice.com/vollrath-resources/warranty-info/warranty-policy.

NOTICE: Use only Vollrath induction-ready insets; failure to do so voids the warranty.

ITEMS

Item	Description (Products for US and Canada)	
74401D	4-qt. Rethermalizer	Includes 1 Inset and 1 Cover
74401DW	4-qt. Warmer	
Accessories	Description	
7440140-DT	Drip Tray	
60178	4-qt. Cover	
88164	4-qt. Inset	
88164NS	4-qt. Nonstick Induction Inset	
83200	Server Pump	

*Nonstick insets are made to order; call Vollrath for minimums and lead time.

FEATURES & BENEFITS

- 400W 3D induction coil heats food evenly and efficiently.
- Units operate without water, eliminating well refilling.
- Sensors in three locations activate the Stir Light.
- Stir light reminds user to mix to reduce burning and waste.
- Advanced controls have highly-visibility LEDs.
- Temperature setting includes °F and °C.
- Six presets for chocolate, cheese, soups, etc., simplify use.
- Locking function prevents unauthorized setting changes.
- Temperature limit of 190 °F decreases burning and waste.
- New easy-to-grip cover handles enhance user experience.
- Included cover and inset provide what is needed for use.
- Additional covers and insets for pre-filling are sold separately.
- Meets NSF4 Performance Requirements for rethermalization and hot-food-holding equipment.
- Bottom-exit 6' cord (1.8 m) power, 58" (1.5 m) control cords, and included hardware simplify installation.

CLEARANCE & REQUIREMENTS

- Use only Vollrath induction-ready insets; failure to do so could cause damage and void the warranty.
- All models require unrestricted air intake and exhaust for proper operation.
- Ensure unit is level to avoid damage during operation.
- Ambient temperature must be at or below 110 °F (43°C) and is measured 1" (2.5 cm) from bottom side of unit while all kitchen appliances are in operation.
- Side clearance is not required.
- Minimum clearance of 4" (10.2 cm) is required at the rear of the unit and any surrounding surfaces for the Control Box.
- To avoid damage, plug the unit into a properly grounded electrical supply that matches the nameplate rating.

DIMENSIONS shown in inches (cm)

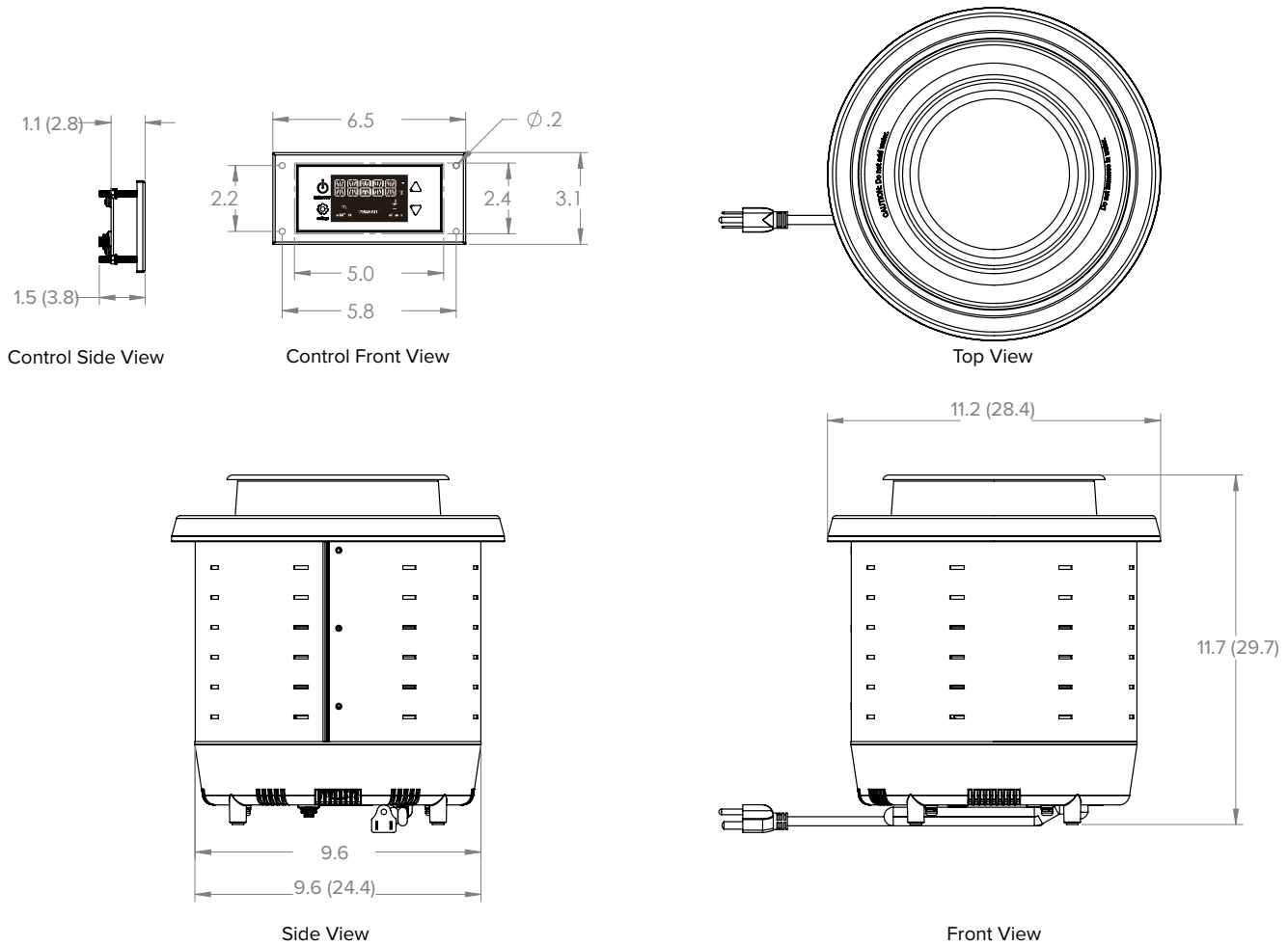

SPECIFICATIONS

Item	Description qt. (L)	Volts	Watts	Amps	Hz	Cutout Dimensions		Dimensions				Shipping Weight & Dimensions (Individual Units)				Plug (Included) & Receptacle
						Unit Diameter	Control Panel	Rim Depth (A)	Base Depth (B)	Width (C)	Height (D)	Weight lb (kg)	W	H	D	
74401D	4 (3.8) Drop-In Rethermalizer	120	400	3.3	50/60	9.8 (25)	6.5 (16.5) x 3.1 (7.9)	11.15 (28.3)	9.6 (24.4)	11.2 (28.4)	11.7 (29.7)	10.1 (4.6)	13.8 (35.1)	15.8 (40.1)	13.8 (35.1)	5-15P (plug)
74401DW	4 (3.8) Drop-In Warmer		250	2.1												5-15R (receptacle)



The Vollrath Company, L.L.C.
 1236 North 18th Street
 Sheboygan, WI 53081-3201 U.S.A.
 Main Tel: 800.624.2051 or 920.457.4851
 Main Fax: 800.752.5620 or 920.459.6573
 Customer Service: 800.628.0830
 Canada Customer Service: 800.695.8560

Technical Services
 techservicereps@vollrathco.com
 Induction Products: 800.825.6036
 Countertop Warming Products: 800.354.1970
 All Other Products: 800.628.0832